

# 25GBASE-ER SFP28 1310nm 40km Industrial DOM Transceiver

SFP28-25GER-31-I-LL



## Application

- 25GBASE ER
- CPRI Option 10 / eCPRI

## Features

- Compliant to SFP28 MSA
- Fully RoHS Compliant
- All Metal Housing for Superior EMI Performance
- Operating Data  
25.78Gbps±100 ppm
- Cooled DML DFB Laser
- APD Receiver
- LC Duplex Connector
- Hot Pluggable 20pin Connector
- Low Power Consumption <2.2W
- -40°C to 85°C Operating Wide Temperature Range
- Single +3.3V Power Supply
- Digital Monitoring SFF-8472 Rev 10.2 Compliant
- Real Time Monitoring of Transmitted Optical Power Received Optical Power ; Laser Bias Current Temperature ; Supply Voltage

## Description

The SFP28 Transceiver is designed for use in Ethernet/eCPRI/ CPRI links up to 25.78 Gb/s data rate and up to 40km link length. They are compliant with SFF8472,SFF-8431,SFF-8432. Digital diagnostics functions are available via a 2-wire serial interface, as specified in SFF-8472.

## Product Specifications

### I. Absolute Maximum Ratings

Parameter	Symbol	Min.	Max.	Unit
<b>Storage Temperature Range</b>	$T_S$	-40	85	°C
<b>Relative Humidity</b>	RH	0	95	%

### II. Optical Characteristics ( $T_{OP} = 0$ to $70$ °C, $V_{CC} = 3.00$ to $3.60$ Volts)

Parameter	Symbol	Min.	Typical	Max.	Unit	Note
<b>Transmitter</b>						
<b>Center Wavelength</b>	$\lambda$	1295		1310	nm	
<b>Side Mode Suppression Ratio</b>	SMSR	30			dB	
<b>Optical Output Power</b>	$P_{av}$	-1		5	dBm	
<b>Extinction Ratio</b>	ER	4			dB	
<b>Transmitter and Dispersion Penalty</b>	TDP			2.7	dB	
<b>Average Launch Power of OFF Transmitter</b>	$P_{OFF}$			-30	dBm	
<b>Relative Intensity Noise</b>	$RIN_{20OMA}$			-130	dB/Hz	

Parameter	Symbol	Min.	Typical	Max.	Unit	Note
<b>Receiver</b>						
<b>Center Wavelength</b>	$\lambda$	1295		1325	nm	
<b>Receiver Sensitivity</b>	R <sub>sen</sub>			-19	dBm	1
<b>Maximum Input Power</b>		-4			dBm	
<b>Optical Return Loss</b>		27			dB	
<b>Assert LOS</b>	LOS <sub>A</sub>	-35			dBm	
<b>De-Assert LOS</b>	LOS <sub>D</sub>			-19	dBm	
<b>LOS Hysteresis</b>		0.5		6	dB	

### III. Qualification Reliability

Feature	Test Method	Performance
<b>Electrostatic Discharge (ESD) to The Electrical Pins</b>	MIL-STD-883C Method 3015.4	Class1 (>1KV) for high speed I/O pins Class 1 (>2KV) for all other pins
<b>Electrostatic Discharge (ESD) to The Duplex LC Receptacle</b>	Variation of IEC 61000-4-2	The SFP28 modules meet ESD requirements given in EN61000-4-2, criterion B test specification such that units are subjected to 15kV air discharges during operation and 8kV direct contact discharges to the case.
<b>Electromagnetic Interference (EMI)</b>	CISPR22 ITE Class BEN55022 Class B	Compliant with standards
<b>EMC</b>		FCC Class B/CE Class B
<b>Immunity</b>	IEC61000-4-3 Class 2 EN55024	Typically show no measurable effect from a 3V/m field swept from 80 to 1000MHz applied to the transceiver without a chassis enclosure.

### IV. Environmental Safety

Feature	Test Method	Performance
<b>RoHS Compliance</b>		Less than 1000 ppm of cadmium, lead, mercury, hexavalent chromium, polybrominated biphenyls, and polybrominated biphenyl ethers.

### V. Typical Application Circuit

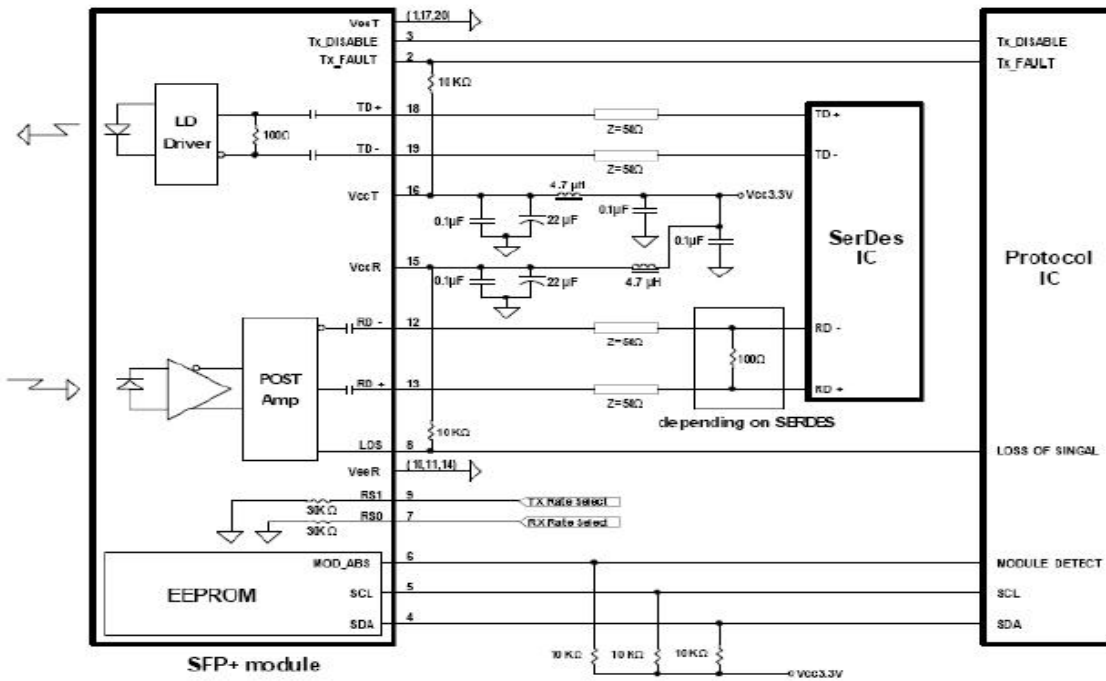

### VI. Mechanical Dimensions

