

25GBASE SFP28 1270nmTX/1330nmRX 20km DOM Industrial Transceiver

SFP28-25G-BX-I-LL

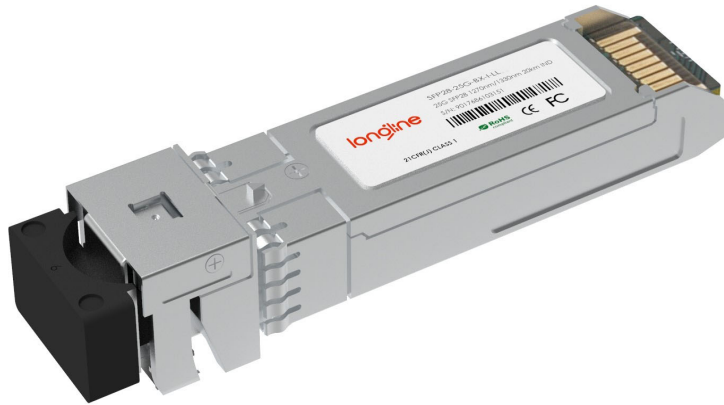

Application

- 25GBASE-LR
- CPRI Option 10 / eCPRI

Standards

- SFF-8472
- SFF-8402
- SFF-8432
- SFF-8431
- CEI-28G-VSR

Features

- Up to 20 km Transmission Distance.
- LC Single Connector
- Low Power Consumption <1.2W
- -40°C to 85°C Operating Case Temperature Range
- Single 3.3V ± 5% Power Supply
- Compliant with SFF-8472

Description

25G BIDI 20KM TX1270nm/RX1330nm is DFB laser based 25 Gb/s SFP28 transceiver. It is designed to transmit and receive optical data up to 20km over single mode fiber. The transceiver is compliant with SFF-8472, SFF-8402, SFF- 8432 and applicable portions of SFF-8431. Digital diagnostics functions are available via a 2-wire serial interface, as specified in SFF-8472.

Product Specifications

I. Absolute Maximum Ratings

Parameter	Symbol	Unit	Min.	Max.
Storage Temperature Range	T _s	°C	-40	85
Relative Humidity	RH	%	0	85
Supply Voltage	V _{CC}	V	-0.3	3.6

II. Recommended Operating Conditions

Parameter	Symbol	Unit	Min.	Typ.	Max.
Operating Case Temperature Range	T _c	°C	-40		85
Power Supply Voltage	V _{CC}	V	3.135	3.3	3.465
Bit Rate	BR	Gb/s	24.33024		25.78125
Max Supported Link Length	L	km	10		20

III. Electrical Characteristics

Parameter	Symbol	Unit	Min.	Typ.	Max.	Note
Supply Voltage	V_{CC}	V	3.14	3.3	3.46	
Supply Current	I_{CC}	mA			360	@3.3V

Transmitter Electrical Characteristics

Input Differential Impedance	R_{IN}	Ω		100		
Single Ended Data Input Swing	V_{IN}	mVp-p	90		450	
Transmit Disable Voltage	V_{DIS}	V	2		V_{CCHOST}	
Transmit Enable Voltage	V_{EN}	V	V_{EE}		$V_{EE}+0.8$	
Transmit Fault Assert Voltage	V_{FA}	V	2.2		V_{CCHOST}	
Transmit Fault De-Assert Voltage	V_{FDA}	V	V_{EE}		$V_{EE}+0.4$	

Receiver Electrical Characteristics

Single Ended Data Output Swing	V_{OD}	mVp-p	200		450	
LOS Fault	V_{LOSFT}	V	2.2		V_{CCHOST}	
LOS Normal	V_{LOSNR}	V	V_{EE}		$V_{EE}+0.4$	

IV. Optical Characteristics

Parameter	Symbol	Unit	Min.	Typ.	Max.	Note
-----------	--------	------	------	------	------	------

Transmitter Optical Characteristics

Center Wavelength Range	λ	nm	1260		1280	Up stream
			1320		1340	Down stream
Spectral Width -20dB		nm			1	
Side Mode Suppression Ratio	SMSR	dB	30			
Average Launch Power	P_{AVG}	dBm	0		6	
OMA Launch Power	P_{OMA}	dBm	-2			
Transmitter and Dispersion Penalty 25G BER=5E-5	TDP	dB			4	
Average Launch Power of OFF Transmitter	P_{OFF}	dBm			-30	
Extinction Ratio	ER	dB	3.5			
RIN20OMA	RIN	dB/Hz			-130	
Optical Return Loss Tolerance		dB			20	
Mask Margin		%	5			1

Parameter	Symbol	Unit	Min.	Typ.	Max.	Note
-----------	--------	------	------	------	------	------

Receiver Optical Characteristics

Center Wavelength Range	λ	nm	1320	1330	1340	Upstream
			1260	1270	1280	Downstream
Overload		dBm	2.5			
OMA Receiver Sensitivity Up to 25G 5E-5	P_{OMA}	dBm			-14	
Assert LOS	LOS_A	dBm	-30			
De-Assert LOS	LOS_D	dBm			-17	
LOS Hysteresis		dB	0.5			

Note 1: Template: {0.31, 0.40, 0.45, 0.34, 0.38, 0.40}, Hit Ratio: 5E-5

V. Pin Function Definitions

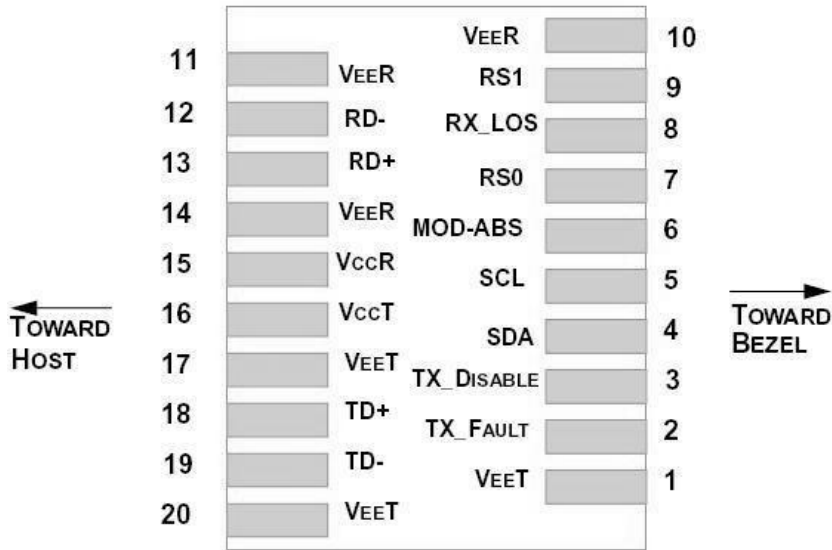

Figure 2 Pin Function Definitions

VI. Transceiver Pin Descriptions

Pin N.	Symbol	Name	Description
1,17,20	VeeT	Transmitter Signal Ground	Connected to signal ground on the host board.
2	TX Fault	LVTTTL Output	Module transmitter fault output
3	TX Disable	LVTTTL Input	Module transmitter disable control
4	SDA	LVTTTL Input/Output	2-wire serial interface data
5	SCL	LVTTTL Input/Output	2-wire serial interface clock
6	MOD-ABS		Module absent (connected to Module ground)
7	RS0	LVTTTL Input	Rate select0(Rx):Low=CDR Bypass;High=CDR Select
8	LOS	LVTTTL Output	Receiver loss of signal

Pin Number	Symbol	Name	Description
9	RS1	LVTTTL Input	Rate select1(Tx):Low=CDR Bypass; High=CDR Select
10,11,14	VeeR		Connected to signal ground on the host board.
12	RD-	CML Output	Receiver inverted data output, internally AC coupled and terminated.
13	RD+	CML Output	Receiver non-inverted data output, internally AC coupled and terminated.
15	VccR		Receiver Power 3.3V Supply
16	VccT		Transmitter Power 3.3V Supply
18	TD+	CML Input	Transmitter non-inverted data input, internally AC coupled and terminated.
19	TD-	CML Input	Transmitter inverted data Input, internally AC coupled and terminated.

VII. Software Control

1.CDR control (Volatile parameter. Reset to default value on boot)

	Hard:Pin#7	Soft:A2h, Byte110dbit3	Mode of Operation	Rate	Note
RS0	0	0	Rx CDR Bypass	Rx: 9.8304Gb/s, 10.1376Gb/s or 10.3125Gb/s	
	0	1	Rx CDR Select	Rx: 24.33024Gb/s or 25.78125Gb/s. Module auto detect data rate and CDR lock accordingly.	Default
	1	0	Rx CDR Select		
	1	1	Rx CDR Select		

	Hard:Pin#9	Soft:A2h, Byte118dBit3	Mode of Operation	Rate	Note
RS1	0	0	Tx CDR Bypass	Tx: 9.8304Gb/s, 10.1376Gb/s or 10.3125Gb/s	
	0	1	Tx CDR Select	Tx: 24.33024Gb/s or 25.78125Gb/s. Module auto detect data rate and CDR lock accordingly.	Default
	1	0	Tx CDR Select		
	1	1	Tx CDR Select		

2.Input EQ and Output Emphasis (Volatile parameter. Reset to default value onboot)

A2H,114d	7-4	Tx Input Equalization@Tx CDR Select	Input Equalization Level Control
	3-0	Tx Input Equalization@Tx CDR Bypass	Input Equalization Level Control
A2H,115d	7-4	RX Output Emphasis@Rx CDR Select	Output Emphasis Level Control
	3-0	RX Output Emphasis@Rx CDR Bypass	Output Emphasis Level Control

ADDRESS A2H BYTE 114d				ADDRESS A2H BYTE 115d			
Code	Transmitter Input Equalization			Code	Receiver Output Emphasis		
	Nominal	Units	Note		Nominal	Units	Note
11xx	Reserved	dB					
1011	Reserved	dB		1xxx	Vendor Specific		
1010	10	dB		0111	7	dB	
1001	9	dB		0110	6	dB	
1000	8	dB		0101	5	dB	
0111	7	dB		0100	4	dB	
0110	6	dB		0011	3	dB	
0101	5	dB		0010	2	dB	
0100	4	dB		0001	1	dB	Default
0011	3	dB		0000	0	No Emphasis	
0010	2	dB	Default				
0001	1	dB					
0000	0	NO EQ					

VIII. Block Diagram

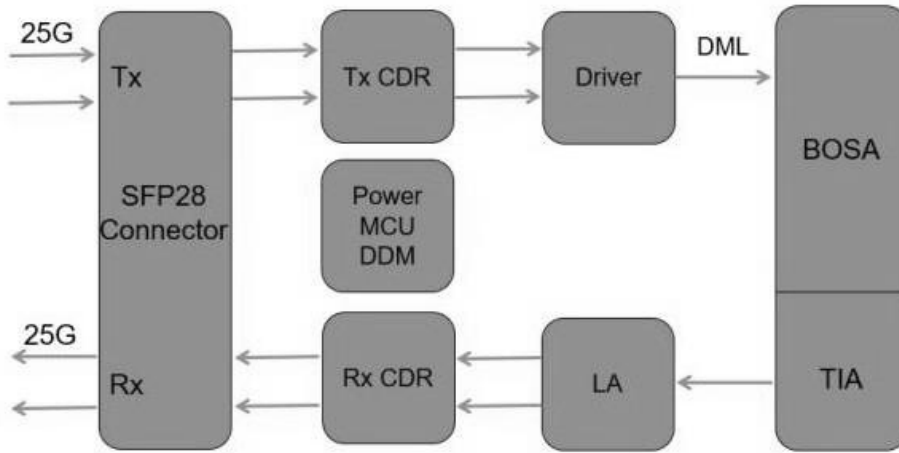

IX. Package Outline

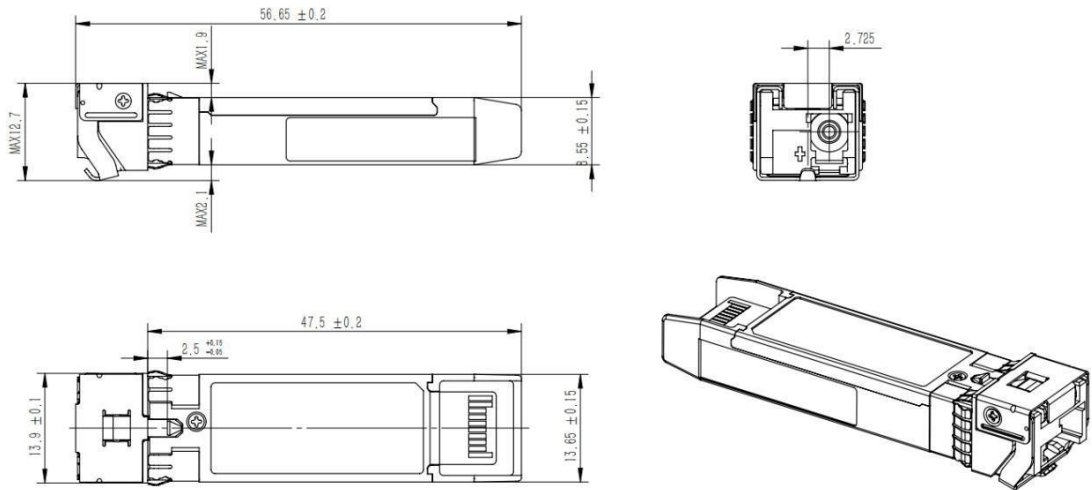

Unit, mm
Unspecified Tolerance: ± 0.1 mm