

# 100BASE-ZX SFP 1550nm 80km DOM LC SMF Transceiver

SFP-FE-LH80-SM1550-LL



## Application

- SONET OC-3/SDH STM-1
- Fast Ethernet
- Other Optical Links

## Features

- Up to 155M b/s Data Links
- Hot-Pluggable
- 1550nm DFB Laser Transmitter
- Duplex LC Connector
- RoHS Compliant and Lead Free
- Up to 80km on 9/125 $\mu$ m SMF
- Single +3.3V Power Supply
- Monitoring Interface Compliant with SFF-8472
- Industrial /Extended/ Commercial Operating Temperature Range: -40 $^{\circ}$ C to 85 $^{\circ}$ C /-5 $^{\circ}$ C to 85 $^{\circ}$ C /0 $^{\circ}$ C to 70 $^{\circ}$ C Version Available

## Description

The 100BASE SFP transceiver is a high performance, cost effective module with a duplex LC optical interface. It can be used for high-speed signals, LVTTTL control and monitoring of signals with standard AC-coupled CML.

The receiver section uses a PIN receiver and the transmitter uses 1550 nm DFB laser, and the 20dB link budget ensures this module SONET OC-3/SDH STM-1 80Km application.

## Specification

### I. Absolute Maximum Ratings

Parameter	Symbol	Min.	Max.	Unit
<b>Storage Temperature Range</b>	$T_S$	-40	85	°C
<b>Supply Voltage</b>	$V_{CC,T,R}$	-0.5	4	°C
<b>Relative Humidity</b>	RH	0	85	%
<b>Case Operating Temperature</b>	<b>Industrial</b>	-40	85	°C
	<b>Extended</b>	-5	85	
	<b>Commercial</b>	0	70	

### II. Recommended Operating Environment

Parameter	Symbol	Min.	Max.	Unit	
<b>Case Operating Temperature</b>	<b>Industrial</b>	-40	85	°C	
	<b>Extended</b>	$T_C$	-5	85	°C
	<b>Commercial</b>		0	70	°C
<b>Supply Voltage</b>	$V_{CC,T,R}$	3.0	3.6	V	

### III. Electrical Characteristics

Parameter	Symbol	Min.	Typ.	Max.	Unit	Note
<b>Supply Voltage</b>	$V_{CC}$	3.0	3.30	3.60	V	
<b>Supply Current</b>	$I_{CC}$		130	170	mA	
<b>Inrush Current</b>	$I_{surge}$			$I_{CC}+30$	mA	
<b>Maximum Power</b>	$P_{max}$			1.0	W	
<b>Transmitter</b>						
<b>Input Differential Impedance</b>	$R_{in}$	90	100	110	W	1
<b>Single Ended Data InPut Swing</b>	$V_{inPP}$	200		1200	mVp-p	
<b>Transmit Disable Voltage</b>	$V_D$	$V_{CC}-1.3$		$V_{CC}$	V	2
<b>Transmit Enable Voltage</b>	$V_{EN}$	$V_{EE}$		$V_{EE}+0.8$	V	
<b>Transmit Disable Assert Time</b>	$T_{dessert}$			10	us	
<b>Receiver</b>						
<b>Single Ended Data Output Swing</b>	$V_{out,pp}$	300		1000	mv	3
<b>Data Output Rise Time</b>	$t_r$			1300	ps	4
<b>Data Output Fall Time</b>	$t_f$			1300	ps	4
<b>LOS Fault</b>	$V_{losfault}$	$V_{CC}-0.5$		$V_{CC\_host}$	V	5
<b>LOS Normal</b>	$V_{losnorm}$	$V_{EE}$		$V_{EE}+0.5$	V	5
<b>Power Supply Rejection</b>	PSR	100			mVpp	6

## IV. Optical Characteristics

Parameter	Symbol	Min.	Typ.	Max.	Unit	Ref.
<b>Transmitter</b>						
<b>Center Wavelength</b>	$\lambda_c$	1480	1550	1580	nm	1
<b>Spectral Width (-20dB)</b>	$\sigma$			1	nm	
<b>Optical Output Power</b>	$P_{out}$	-5		0	dBm	2
<b>Optical Rise / Fall Time</b>	$t_r/t_f$			1300	ps	3
<b>Extinction Ratio</b>	ER	9.2			dB	
<b>Eye Mask for Optical Output</b>	Compliant with Eye Mask Defined in IEEE802.3 Standard					
<b>Receiver</b>						
<b>Optical Input Wavelength</b>	$\lambda$	1100		1670	nm	
<b>Optical Input Power</b>	$P_{in}$	-36		-3	dBm	4.5
<b>Receiver Reflectance</b>		12			dB	
<b>Receiver Overload</b>	$P_{ol}$			-3	dBm	4.5
<b>RX Sensitivity</b>	$S_{en}$			-34	dBm	4.5
<b>RX_LOS Assert</b>	$LOS_A$	-44			dBm	
<b>RX_LOS Deassert</b>	$LOS_D$			-35	dBm	
<b>RX_LOS Hysteresis</b>	$LOS_H$		2	2.5	dB	

Parameter	Symbol	Min.	Typ.	Max.	Unit	Ref.
-----------	--------	------	------	------	------	------

### General Specifications

<b>Data Rate</b>	BR		155		Mb/s	
<b>Bit Error Rate</b>	BER			10 <sup>-12</sup>		
<b>Max. Supported Link Length on 9/125µm SMF@155Mb/s</b>	L <sub>MAX</sub>		80		Km	6
<b>Total System Budget</b>	LB	20			dB	7

#### Notes:

- Also specified to meet curves in FC-PI 13.0 Figures 18 and 19, which allow trade-off between wavelength spectral width.
- Class 1 Laser Safety per FDA/CDRH and EN (IEC) 60825 regulations.
- Unfiltered, 20-80%. Complies with IEEE 802.3 (Gig. E), FC 1x and 2x eye masks when filtered.
- Measured with conformance signals defined in FC-PI 13.0 specifications.
- Measured with PRBS 231 -1 at 10<sup>-12</sup> BER.
- Dispersion limited per FC-PI Rev. 13.
- Attenuation of 0.25 dB/km is used for the link length calculations. Distances are indicative only. Please refer to the Optical Specifications in Table IV to calculate a more accurate link budget based on specific conditions in your application.

## V. Digital Diagnostic Monitor Characteristics

Parameter	Symbol	Min.	Max.	Unit
<b>Temperature Monitor Absolute Error</b>	DMI_Temp	-3	3	degC
<b>Laser Power Monitor Absolute Error</b>	DMI_TX	-3	3	dB
<b>RX Power Monitor Absolute Error</b>	DMI_RX	-3	3	dB
<b>Supply Voltage Monitor Absolute Error</b>	DMI_V <sub>CC</sub>	-0.08	0.08	V
<b>Bias Current Monitor</b>	DMI_I <sub>bias</sub>	-10%	10%	mA

### VI. Block Diagram of Transceiver

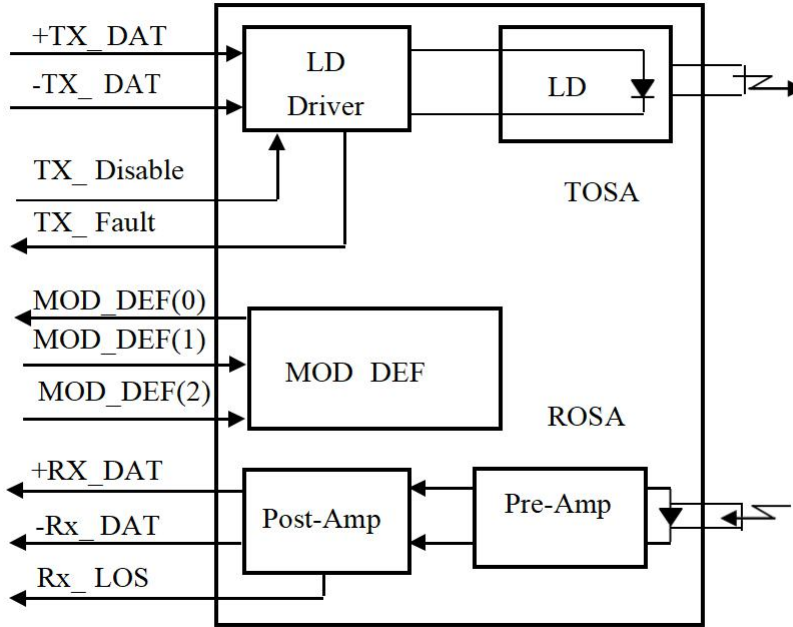

### VII. Pin Configuration

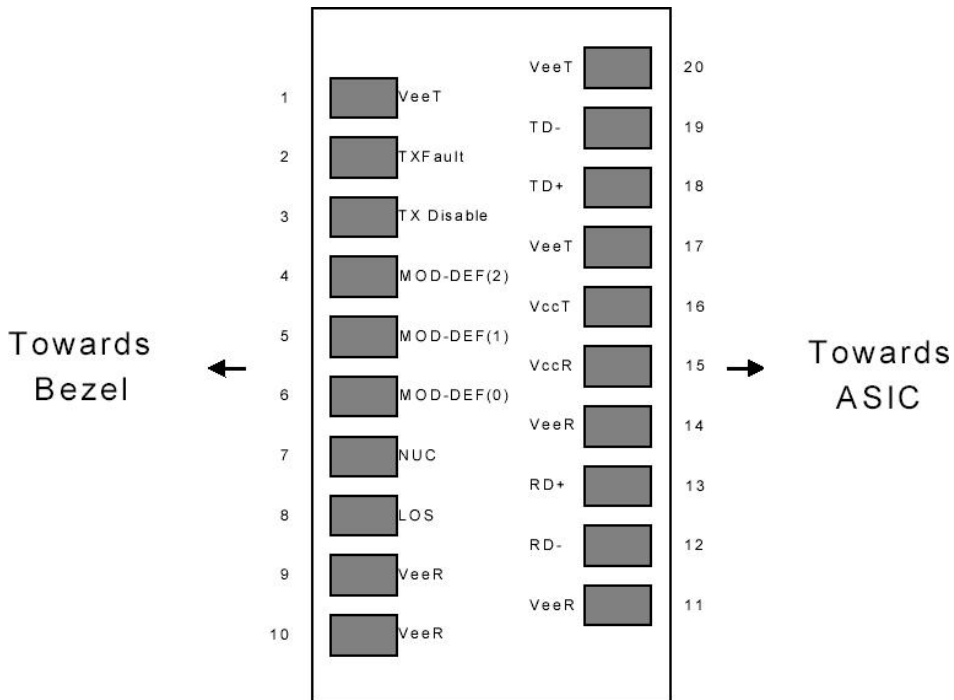

## VIII. Transceiver Pin Descriptions

Pin No.	Name	Function	PlugSeq	Notes
1	$V_{EE}T$	Transmitter Ground	1	1
2	TX Fault	Transmitter Fault Indication	3	
3	TX Disable	Transmitter Disable	3	2
4	MOD-DEF2	Module Definition	2	3
5	MOD-DEF1	Module Definition1	3	3
6	MOD-DEF0	Module Definition0	3	3
7	Rate Select	Not Connected	3	4
8	LOS	Loss of Signal	3	5
9	$V_{EE}R$	Receiver Ground	1	1
10	$V_{EE}R$	Receiver Ground	1	1
11	$V_{EE}R$	Receiver Ground		1
12	RD-	Inv. Received Data Out	3	6
13	RD+	Received Data Out	3	6
14	$V_{EE}R$	Receiver Ground	3	1
15	$V_{CC}R$	Receiver Power	2	1
16	$V_{CC}T$	Transmitter Power	2	
17	$V_{EE}T$	Transmitter Ground	1	
18	TD+	Transmit Data In	3	6
19	TD-	Inv. Transmit In	3	6
20	$V_{EE}T$	Transmitter Ground	1	

### IX. Principle Diagram

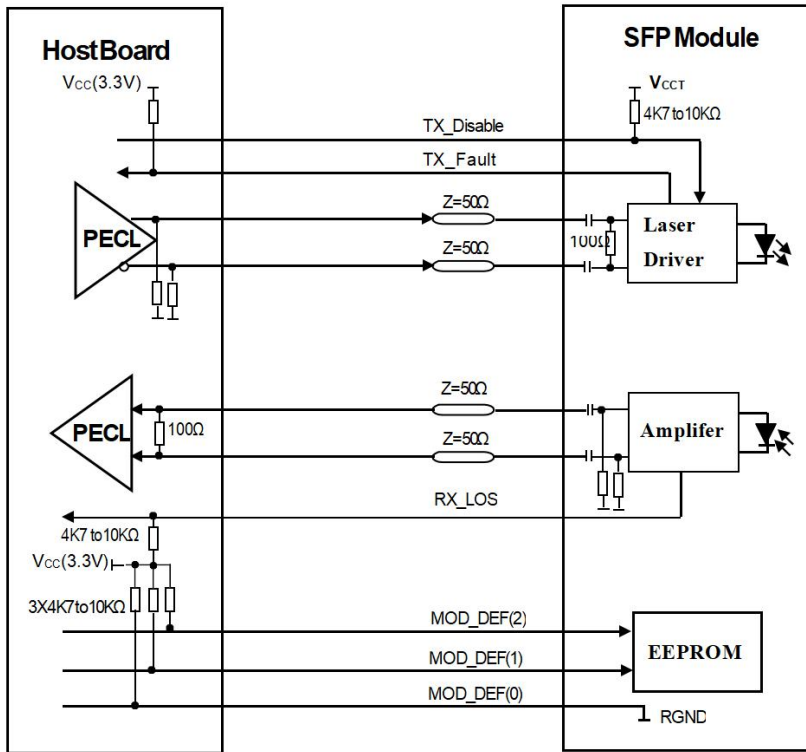

### X. Mechanical Dimensions

