

# 100BASE-BX BiDi SFP 1310nm-TX/1550nm-RX 10km DOM LC SMF Transceiver

SFP-FE-10-SM1310-BIDI-LL



## Applications

- Fast Ethernet
- SDH STM-1/ SONET OC-03
- WDM Application

## Features

- Single Mode bi-directional Transmission
- SFP Multi-source Package with LC Receptacle
- Up to 155Mb/s Data Links
- Hot-Pluggable Capability
- Up to 10 km on 9/125 $\mu$ m SMF
- Single +3.3V Power Supply
- Built-in WDM
- Isolation > 30dB, Cross Talk < -45dB
- Metal Enclosure, Excellent EMI & ESD Protection
- Monitoring Interface Compliant with SFF-8472
- Compliant with Specifications for IEEE802.3
- Compliant with Bellcore TA-NWT-000983
- Eye Safety Designed to Meet Laser Class1, Compliant with IEC60825-1
- RoHS Compliant

## Description

Bi-Directional transceiver is a high performance, cost effective module, which is compliant with LC Optics interface with built in WDM for Bi-Directional serial optical data communication applications. This module is designed for Single-Mode single fiber, operates at the normal wavelength of 1310/1550nm.

## Product Specifications

### I. Absolute Maximum Ratings

Parameter	Symbol	Min.	Typical	Max.	Unit	
Storage Temperature	$T_s$	-40		+85	°C	
Supply Voltage	$V_{CC,T,R}$	-0.5		4	V	
Relative Humidity	RH	0		85	%	
Case Operating Temperature	Industrial	Top	-40		85	°C
	Extended		-5		85	
	Commercial		0		70	

### II. Recommended Operating Environment

Parameter	Symbol	Min.	Typical	Max.	Unit	
Case Operating Temperature	Industrial	TC	-40		85	°C
	Extended		-5		85	
	Commercial		0		+70	
Supply Voltage	$V_{CC,T,R}$	3.0		3.6	V	

**III. Electrical Characteristics (TOP = 0 to 70 ° C,  $V_{CC} = 3.0$  to 3.60 Volts)**

Parameter	Symbol	Min.	Typical	Max.	Unit	Note
Supply Voltage	$V_{CC}$	3.0	3.30	3.60	V	
Supply Current	$I_{CC}$			300	mA	
Inrush Current	$I_{surge}$			$I_{CC}+30$	mA	
Maximum Power	$P_{max}$			1.0	W	
<b>Transmitter Section</b>						
Input Differential Impedance	$R_{in}$	90	100	110	W	1
Single Ended Data Input Swing	$V_{in,PP}$	200		1200	mVp-p	
Transmit Disable Voltage	$V_D$	$V_{CC}-1.3$		$V_{CC}$	V	2
Transmit Enable Voltage	$V_{EN}$	$V_{ee}$		$V_{ee}+0.8$	V	
Transmit Disable Assert Time	$T_{dessert}$			10	us	
<b>Receiver Section</b>						
Single Ended Data Output Swing	$V_{out, pp}$	300		1000	mv	3
Data Output Rise Time	$t_r$			1300	ps	4
Data Output Fall Time	$t_f$			1300	ps	4
LOS Fault	$V_{losfault}$	$V_{CC}-0.5$		$V_{CC\_host}$	V	5
LOS Normal	$V_{los norm}$	$V_{ee}$		$V_{ee}+0.5$	V	5
Power Supply Rejection	PSR	100			mVpp	6

**Note:**

1. AC coupled.
2. Or open circuit.
3. Into 100 ohm differential termination.
4. 20 – 80 %
5. LOS is LVTTTL. Logic 0 indicates normal operation; logic 1 indicates no signal detected.
6. All transceiver specifications are compliant with a power supply sinusoidal modulation of 20 Hz to 1.5MHz up to specified value applied through the power supply filtering network shown on page 23 of the Small Form-factor Pluggable (SFP) Transceiver Multi-Source Agreement (MSA), September 14, 2000.

**IV. Optical Parameters (TOP = 0 to 70 ° C, V<sub>CC</sub> = 3.0 to 3.60 Volts)**

Parameter	Symbol	Min.	Typical	Max.	Unit	Note
-----------	--------	------	---------	------	------	------

**Transmitter Section**

<b>Center Wavelength</b>	$\lambda_c$	1270	1310	1360	nm	1
--------------------------	-------------	------	------	------	----	---

<b>Spectral Width</b>	$\sigma$			3	nm	
-----------------------	----------	--	--	---	----	--

<b>Optical Output Power</b>	$P_{out}$	-15		-8	dBm	2
-----------------------------	-----------	-----	--	----	-----	---

<b>Optical Rise/Fall Time</b>	$t_r/t_f$			1300	ps	3
-------------------------------	-----------	--	--	------	----	---

<b>Extinction Ratio</b>	ER	9.2			dB	
-------------------------	----	-----	--	--	----	--

**Eye Mask for Optical Output**

Compliant with Eye Mask Defined in IEEE 802.3 standard

<b>Relative Intensity Noise</b>	RIN			-120	dB/Hz	
---------------------------------	-----	--	--	------	-------	--

**Receiver Section**

<b>Optical Input Wavelength</b>	$\lambda$	1480	1550	1580	nm	
---------------------------------	-----------	------	------	------	----	--

<b>Optical Input Power</b>	$P_{in}$	-34		-3	dBm	4.5
----------------------------	----------	-----	--	----	-----	-----

<b>Receiver Reflectance</b>		12			dB	
-----------------------------	--	----	--	--	----	--

Parameter	Symbol	Min.	Typical	Max.	Unit	Note
<b>Receiver Overload</b>	Pol			-3	dBm	4.5
<b>RX Sensitivity</b>	Sen			-34	dBm	4.5
<b>RX_LOS Assert</b>	LOSA	-45			dBm	
<b>RX_LOS Deassert</b>	LOSD			-35	dBm	
<b>RX_LOS Hysteresis</b>	LOSH		2	2.5	dB	
<b>General Specifications</b>						
<b>Data Rate</b>	BR		155		Mb/s	
<b>Bit Error Rate</b>	BER			10 <sup>-12</sup>		
<b>Max.Supported Link Length on 9/125 μm SMF @ 1.25G</b>	LMAX		10		km	6
<b>Total System Budget</b>	LB	19			dB	6

## Notes:

1. Also specified to meet curves in FC-PI 13.0 Figures 18 and 19, which allow trade-off between wavelength spectral width.
2. Class 1 Laser Safety per FDA/CDRH and EN (IEC) 60825 regulations.
3. Unfiltered, 20-80%. Complies with IEEE 802.3 (Gig. E), FC 1x and 2x eye masks when filtered.
4. Measured with conformance signals defined in FC-PI 13.0 specifications.
5. Measured with PRBS 231 -1at 10-12 BER
6. Dispersion limited per FC-PI Rev. 13
7. Attenuation of 0.45 dB/km is used for the link length calculations. Distances are indicative only. Please refer to the Optical Specifications in Table IV to calculate a more accurate link budget based on specific conditions in your application.

### V. Digital Diagnostic Monitor Characteristics

The following digital diagnostic characteristics are defined over the Recommended Operating Environment unless otherwise specified. It is compliant to SFF8472 Rev10.2 with internal calibration mode. For external calibration mode please contact our sales staff.

Parameter	Symbol	Min.	Max.	Unit
Temperature Monitor Absolute Error	DMI_Temp	-3	3	degC
Laser Power Monitor Absolute Error	DMI_TX	-3	3	dB
RX Power Monitor Absolute Error	DMI_RX	-3	3	dB
Supply Voltage Monitor Absolute Error	DMI_Vcc	-0.1	0.1	V
Bias Current Monitor Absolute Error	DMI_Ibias	-10%	10%	mA

### VI. Digital Diagnostic Monitor Characteristics

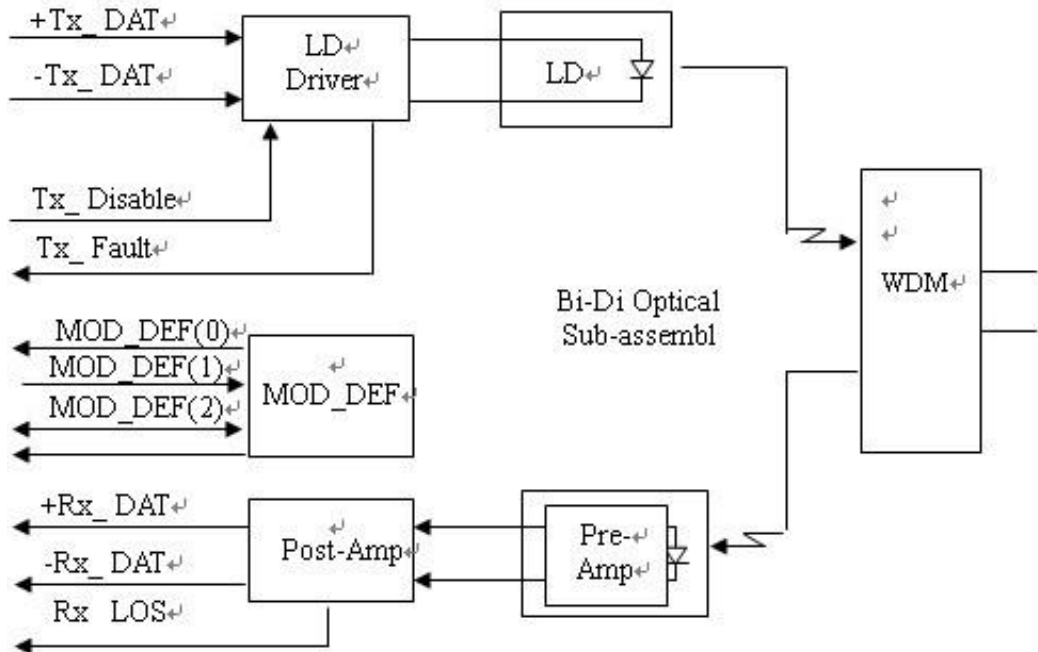

Figure1: Block Diagram

## VII. Pin Description

Pin No	Name	Function	Plug Seq	Notes
1	$V_{eeT}$	Transmitter Ground	1	1
2	TX Fault	Transmitter Fault Indication	3	
3	TX Disable	Transmitter Disable	3	2
4	MOD-DEF2	Module Definition	2	3
5	MOD-DEF1	Module Definition 1	3	3
6	MOD-DEF0	Module Definition 0	3	3
7	Rate Select	Not Connected	3	4
8	LOS	Loss of Signal	3	5
9	$V_{eeR}$	Receiver Ground	1	1
10	$V_{eeR}$	Receiver Ground	1	1
11	$V_{eeR}$	Receiver Ground		1
12	RD-	Inv.Received Data Out	3	6
13	RD+	Received Data Out	3	6
14	$V_{eeR}$	Receiver Ground	3	1
15	$V_{ccR}$	Receiver Power	2	1
16	$V_{ccT}$	Transmitter Power	2	

Pin No	Name	Function	Plug Seq	Notes
17	V <sub>ee</sub> T	Transmitter Ground	1	
18	TD+	Transmit Data In	3	6
19	TD-	Inv.TransmitIn	3	6
20	V <sub>ee</sub> T	Transmitter Ground	1	

**Notes:**

1. Circuit ground is internally isolated from chassis ground.
2. Laser output disabled on TDIS >2.0V or open, enabled on TDIS <0.8V.
3. Should be pulled up with 4.7k - 10 kohms on host board to a voltage between 2.0V and 3.6V.MOD\_DEF(0) pulls line low to indicate module is plugged in.
4. Rate select is not used.
5. LOS is open collector output. Should be pulled up with 4.7k – 10 kohms on host board to a voltage between 2.0V and 3.6V. Logic 0 indicates normal operation; logic 1 indicates loss of signal.
6. AC Coupled.

**VII. Recommended Circuit**

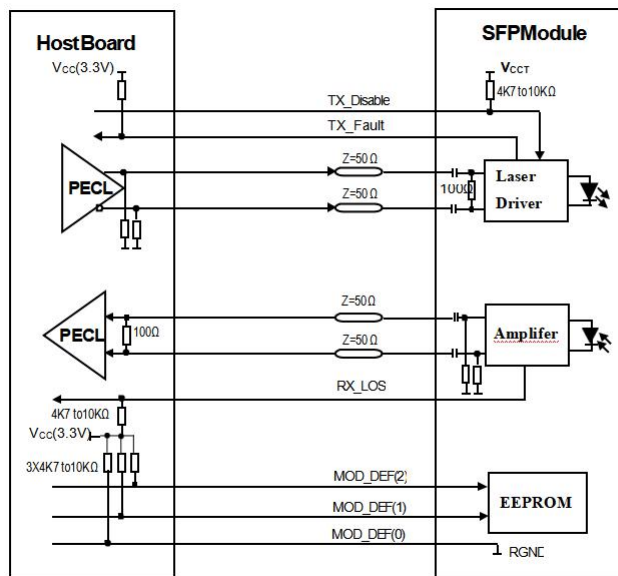

Figure 2 . SFP Host Recommended Circuit



Data Address	Length(Byte)	Name of Length	Description and Contents
<b>Base ID Fields</b>			
<b>0</b>	1	Identifier	Type of Longline serial transceiver (03h=SFP)
<b>1</b>	1	Reserved	Extended identifier of type serial transceiver(04h)
<b>2</b>	1	Connector	Code of optical connector type (07=LC)
<b>3-10</b>	8	Transceiver	Fast Ethernet 100Base-BX
<b>11</b>	1	Encoding	4B 5B(02h)
<b>12</b>	1	BR, Nominal	Nominal baud rate, unit of 100Mbps
<b>13</b>	1	Reserved	(0000h)
<b>14</b>	1	Length (9um,km)	Link length supported for 9/125um fiber, units of km
<b>15</b>	1	Length (9um)	Link length supported for 9/125um fiber, units of 100m
<b>16</b>	1	Length (50um)	Link length supported for 50/125um fiber, units of 10m
<b>17</b>	1	Length (62.5um)	Link length supported for 62.5/125um fiber, units of 10m
<b>18</b>	1	Length (Copper)	Link length supported for copper, units of meters
<b>19</b>	1	Reserved	
<b>20-35</b>	16	Vendor Name	SFP vendor name:
<b>36</b>	1	Reserved	
<b>37-39</b>	3	Vendor OUI	SFP transceiver vendor OUI ID

Data Address	Length(Byte)	Name of Length	Description and Contents
<b>40-55</b>	16	Vendor PN	PartNumber: "LonglineXXXXXX" (ASCII)
<b>56-59</b>	4	Vendor rev	Revision level for part number
<b>60-61</b>	2	Wavelength	Laser wavelength
<b>62</b>	1	Reserved	
<b>63</b>	1	CCID	Least significant byte of sum of data in address 0-62
<b>Extended ID Fields</b>			
<b>64-65</b>	2	Option	Indicates which optical SFP signals are implemented (001Ah=LOS, TX_FAULT, TX_DISABLE all supported)
<b>66</b>	1	BR, max	Upper bit rate margin, units of %
<b>67</b>	1	BR, min	Lower bit rate margin, units of %
<b>68-83</b>	16	Vendor SN	Serial number (ASCII)
<b>84-91</b>	8	Date code	Manufacturing date code
<b>92</b>	1	Diagnostic Type	Diagnostics
<b>93</b>	1	Enhanced Options	Diagnostics
<b>94</b>	1	SFF-8472	Diagnostics
<b>95</b>	1	CCEX	Check code for the extended ID Fields (addresses 64 to 94)
<b>Vendor Specific ID Fields</b>			
<b>96-127</b>	32	Readable	Vendor specific data, readonly

## VIII. Diagnostics Memory Contents(A2h)

Data Address	Length (Byte)	Name of Length	Description and Contents
<b>Diagnostic and control/status fields</b>			
<b>0-39</b>	40	A/W Thresholds	Diagnostic Flag Alarm and Warning Thresholds
<b>40-55</b>	16	Unallocated	
<b>56-91</b>	16	Ext Cal Constants	Diagnostic calibration constants for optional External Calibration
<b>92-94</b>	3	Unallocated	
<b>95</b>	1	CC_DMI	Check code for Base Diagnostic Fields (addresses 0 to 94)
<b>96-105</b>	10	Diagnostics	Diagnostic Monitor Data (internally orexternally calibrated)
<b>106-109</b>	4	Unallocated	
<b>110</b>	1	Status/Control	Optional Status and Control Bits
<b>111</b>	1	Reserved	Reserved for SFF-8079
<b>112-113</b>	2	Alarm Flags	Diagnostic Alarm Flag Status Bits
<b>114-115</b>	2	Unallocated	
<b>116-117</b>	2	Warning Flags	Diagnostic Warning Flag Status Bits
<b>118-119</b>	2	ExtStatus/Control	Extended module control and status bytes
<b>General Use Fields</b>			
<b>120-127</b>	8	Vendor Specific	Vendor specific memory addresses

Data Address	Length (Byte)	Name of Length	Description and Contents
128-247	120	User EEPROM	User writable non-volatile memory
248-255	8	Vendor Control	Vendor specific control addresses

### IX. Mechanical Dimensions

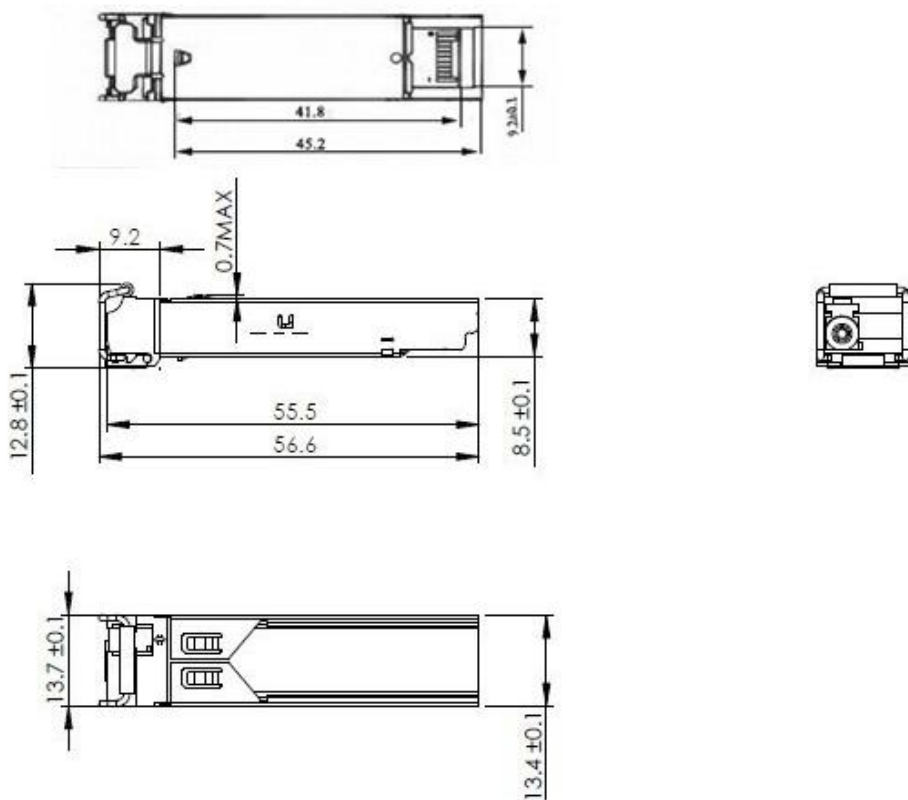

Figure 3. Mechanical Drawing