

# OC-48/STM-16 SR-0 SFP 850nm 300m Transceiver

SFP-2GSR-85-LL



## Applications

- SDH STM-16
- SONET OC48
- 1X/2X Fiber Channel
- Other Optical Link

## Features

- Up to 2.5Gb/s Data Links
- Hot-Pluggable
- 850nm VCSEL laser transmitter
- Duplex LC connector
- RoHS compliant and Lead Free
- Up to 300m on 50/125µm MMF
- Single +3.3V Power Supply
- Monitoring Interface Compliant with SFF-8472
- Industrial /Extended/ Commercial operating temperature range: -40°C to 85°C / -5°C to 85°C / -0°C to 70°C Version available

## Description

SFP-2GSR-85-LL Transceiver is a high performance, cost effective module which have a Duplex LC optics interface. Standard AC coupled CML signal and LVTTTL control and monitor signals. The receiver section uses a PIN receiver and the transmitter uses 850 nm VCSEL laser, up to 7dB link budge ensure this module STM-16/OC-48 300m application.

## Product Specifications

### I. Absolute Maximum Conditions

Parameter	Symbol	Min.	Max.	Unit
<b>Storage Temperature</b>	$T_S$	-40	85	°C
<b>Relative Humidity</b>	RH	0	85	%
<b>Supply Voltage</b>	$V_{CC,T,R}$	-0.5	4	V
<b>Case Operating Temperature</b>	Industrial	-40	85	°C
	Extended	5	85	
	Commercial	0	70	

### II. Recommended Operating Environment

Parameter	Symbol	Min.	Max.	Unit
<b>Supply Voltage</b>	$V_{CC,T,R}$	3.0	3.6	V
<b>Case Operating Temperature</b>	Industrial	-40	85	°C
	Extended	5	85	
	Commercial	0	70	

### III. Electrical Characteristics

Parameter	Symbol	Min.	Typ	Max.	Unit	Notes
<b>Supply Voltage</b>	$V_{cc}$	3.0	3.30	3.60	V	
<b>Supply Current</b>	$I_{cc}$		160	280	mA	
<b>Transmitter Section</b>						
<b>Input differential impedance</b>	$R_{in}$	90	100	110	$\Omega$	1
<b>Single ended data input swing</b>	$V_{inPP}$	200		1200	mVp-p	
<b>Transmit Disable Voltage</b>	$V_D$	$V_{cc}-1.3$		$V_{cc}$	V	2
<b>Transmit Enable Voltage</b>	$V_{EN}$	$V_{ee}$		$V_{ee}+0.8$	V	
<b>Transmit Disable Assert Time</b>	$T_{dessert}$			10	us	
<b>Receiver Section</b>						
<b>Single ended data output swing</b>	$V_{out,pp}$	300		1000	mv	3
<b>Data output rise time</b>	$t_r$			260	ps	4
<b>Data output fall time</b>	$t_f$			260	ps	4
<b>LOS Fault</b>	$V_{iosfault}$	$V_{cc}-0.5$		$V_{CC\_host}$	V	5
<b>LOS Normal</b>	$V_{iosnorm}$	$V_{ee}$		$V_{ee}+0.5$	V	5
<b>Power Supply Rejection</b>	PSR	100			mVpp	6
<b>Total Generated Receiver Jitter (peak to peak)</b>	$J_{RXP-P}$			0.07	UI	
<b>Total Generated Receiver Jitter (rms)</b>	$J_{RXRMS}$			0.007	UI	

**Notes:**

1. AC coupled.
2. Or open circuit.
3. Into 100 ohm differential termination.
4. 20 – 80 %
5. LOS is LVTTTL. Logic 0 indicates normal operation; logic 1 indicates no signal detected.
6. All transceiver specifications are compliant with a power supply sinusoidal modulation of 20 Hz to 1.5MHz up to specified value applied through the power supply filtering network shown on page 23 of the Small Form-factor Pluggable (SFP) Transceiver Multi-Source Agreement (MSA), September 14, 2000.

## IV. Optical Parameters

Parameter	Symbol	Min.	Typ	Max.	Unit	Notes
<b>Transmitter Section</b>						
<b>Center Wavelength</b>	$\lambda_c$	830	850	860	nm	1
<b>Spectral Width</b>	$\sigma$			0.85	nm	
<b>Optical Output Power</b>	$P_{out}$	-10		-3	dBm	2
<b>Optical Rise/Fall Time</b>	$t_r/t_f$			260	ps	3
<b>Extinction Ratio</b>	ER	8.2			dB	
<b>Total Generated Transmitter Jitter (peak to peak)</b>	$J_{TXP-P}$			0.07	UI	
<b>Total Generated Transmitter Jitter (rms)</b>	$J_{TXrms}$			0.007	UI	
<b>Eye Mask for Optical Output</b>	$\lambda_c$	830	850	860	nm	1
<b>Receiver Section</b>						
<b>Optical Input Wavelength</b>		770		860	nm	
<b>RX Sensitivity</b>	$S_{en}$			-17	dBm	4.5
<b>Receiver Overload</b>	$P_{ol}$			-3	dBm	4.5

Parameter	Symbol	Min.	Typ	Max.	Unit	Notes
<b>RX_LOS Assert</b>	LOS <sub>A</sub>	-30			dBm	
<b>RX_LOS Deassert</b>	LOS <sub>D</sub>			-18	dBm	
<b>RX_LOS Hysteresis</b>	LOS <sub>H</sub>	0.5		4	dB	

### General Specifications

<b>Data Rate</b>	BR	2125		2500	Mb/s	
<b>Bit Error Rate</b>	BER			10-12		
<b>Max. Supported Link Length on 50/125µm MMF@2.5Gb/s</b>	LMAX			300	m	6
<b>Total System Budget</b>	LB	7			dB	7

#### Notes:

1. Also specified to meet curves in FC-PI 13.0 Figures 18 and 19, which allow trade-off between wavelength spectral width.
2. Class 1 Laser Safety per FDA/CDRH and EN (IEC) 60825 regulations.
3. Unfiltered, 20-80%. Complies with IEEE 802.3 (Gig. E), FC 1x and 2x eye masks when filtered.
4. Measured with conformance signals defined in FC-PI 13.0 specifications.
5. Measured with PRBS 27 -1at 10-12 BER
6. Dispersion limited per FC-PI Rev. 13
7. Attenuation of 3.5 dB/km is used for the link length calculations. Distances are indicative only. Please refer to the Optical Specifications in Table IV to calculate a more accurate link budget based on specific conditions in your application.

## V. Digital Diagnostic Monitoring Characteristics

The following digital diagnostic characteristics are defined over the Recommended Operating Environment unless otherwise specified. It is compliant to SFF8472 Rev10.2 with internal calibration mode. For external calibration mode please contact our sales staff.

Parameter	Symbol	Min.	Max.	Unit
<b>Temperature monitor absolute error</b>	DMI_Temp	-3	3	degC
<b>Laser power monitor absolute error</b>	DMI_TX	-3	3	dB
<b>RX power monitor absolute error</b>	DMI_RX	-3	3	dB
<b>Supply voltage monitor absolute error</b>	DMI_VCC	-0.1	0.1	V
<b>Bias current monitor absolute error</b>	DMI_Ibias	-10%	10%	mA

## VI. Block Diagram of Transceiver

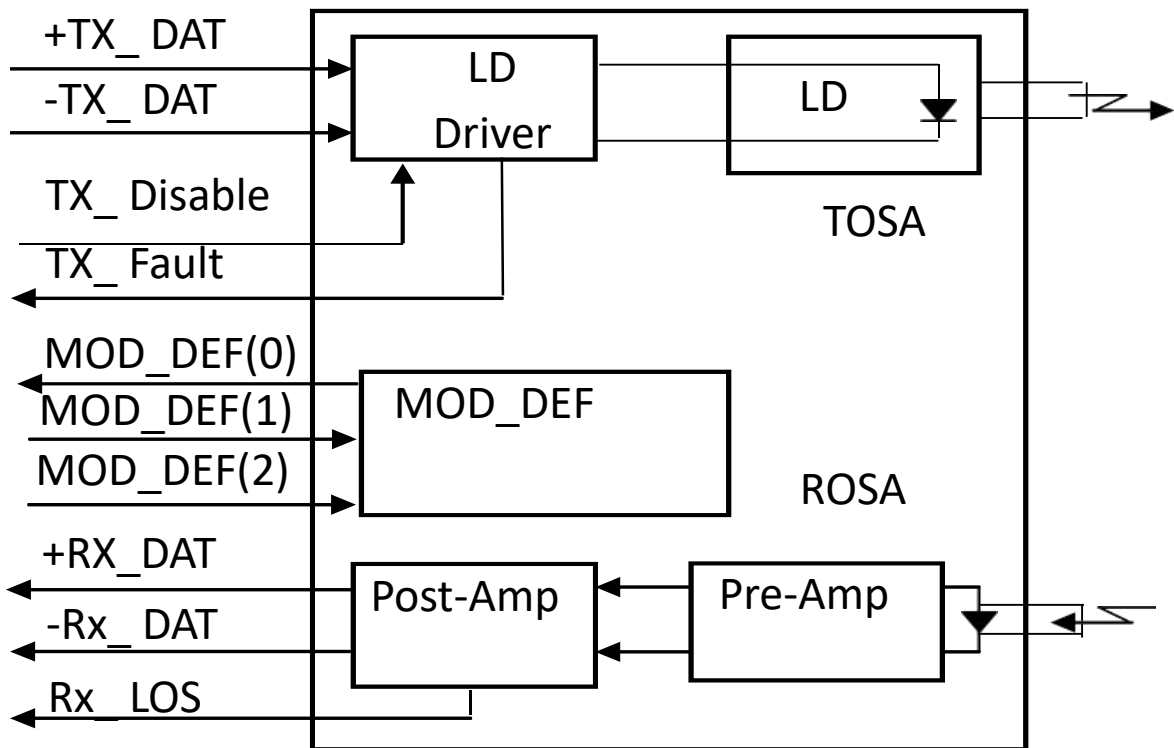

Figure 1. Block Diagram

### VII. Pin Assignment

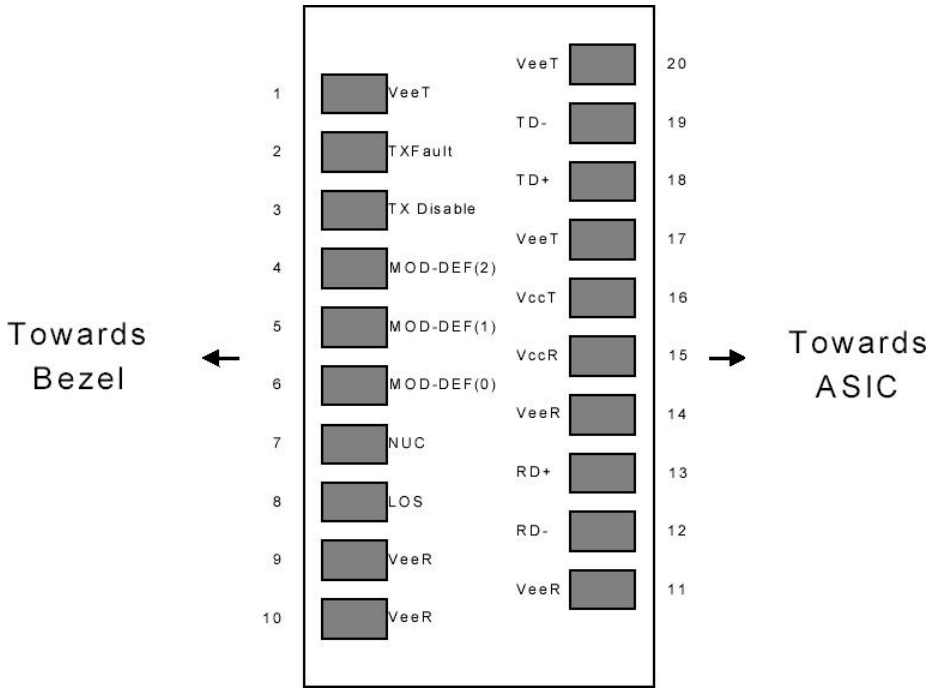

Figure 2. Diagram of Host Board Connector Block Pin Numbers and Names

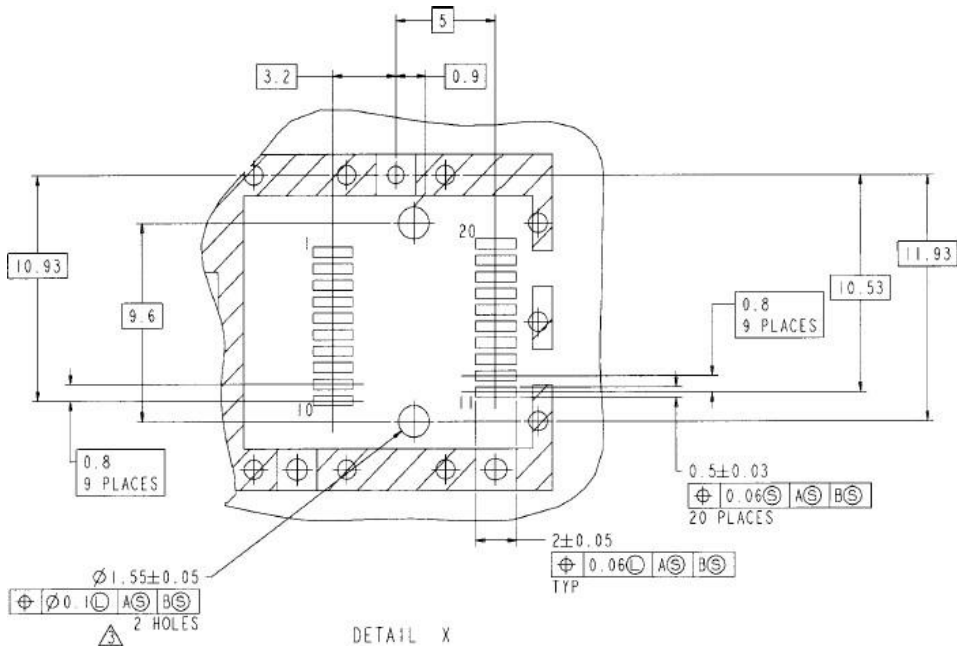

Figure 3. SFP Host Board Mechanical Layout

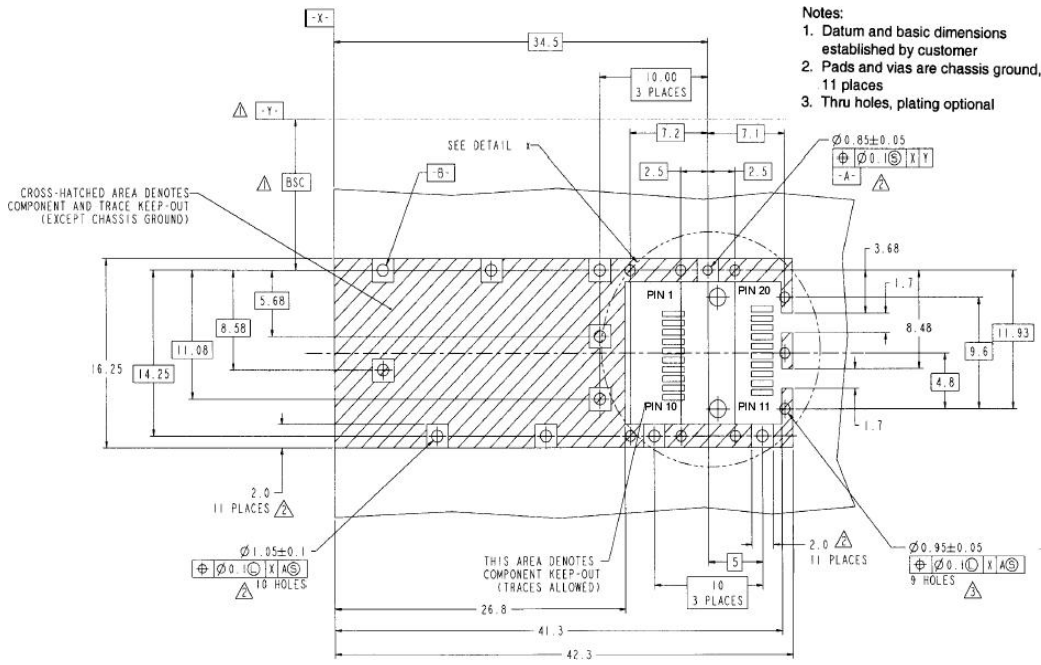

Figure 4. SFP Host Board Mechanical Layout(Cont)

## VIII. Pin Description

Pin No	Name	Function	Plug Seq	Notes
1	VeeT	TransmitterGround	1	1
2	TXFault	TransmitterFaultIndication	3	
3	TXDisable	TransmitterDisable	3	2
4	MOD-DEF2	ModuleDefinition	2	3
5	MOD-DEF1	ModuleDefinition1	3	3
6	MOD-DEF0	ModuleDefinition0	3	3
7	RateSelect	Not Connected	3	4
8	LOS	Loss of Signal	3	5



Pin No	Name	Function	Plug Seq	Notes
9	VeeR	Receiver Ground	1	1
10	VeeR	Receiver Ground	1	1
11	VeeR	Receiver Ground		1
12	RD-	Inv.ReceivedDataOut	3	6
13	RD+	ReceivedDataOut	3	6
14	VeeR	Receiver Ground	3	1
15	VccR	ReceiverPower	2	1
16	VccT	TransmitterPower	2	
17	VeeT	TransmitterGround	1	
18	TD+	TransmitDataIn	3	6
19	TD-	Inv.TransmitIn	3	6
20	VeeT	TransmitterGround	1	

**Notes:**

1. Circuit ground is internally isolated from chassis ground.
2. Laser output disabled on TDIS >2.0V or open, enabled on TDIS <0.8V.
3. Should be pulled up with 4.7k - 10 kohms on host board to a voltage between 2.0V and 3.6V.MOD\_DEF(0) pulls line low to indicate module is plugged in.
4. Rate select is not used
5. LOS is open collector output. Should be pulled up with 4.7k – 10 kohms on host board to a voltage between 2.0V and 3.6V. Logic 0 indicates normal operation; logic 1 indicates loss of signal.
6. AC Coupled

### IX. Recommended Circuit

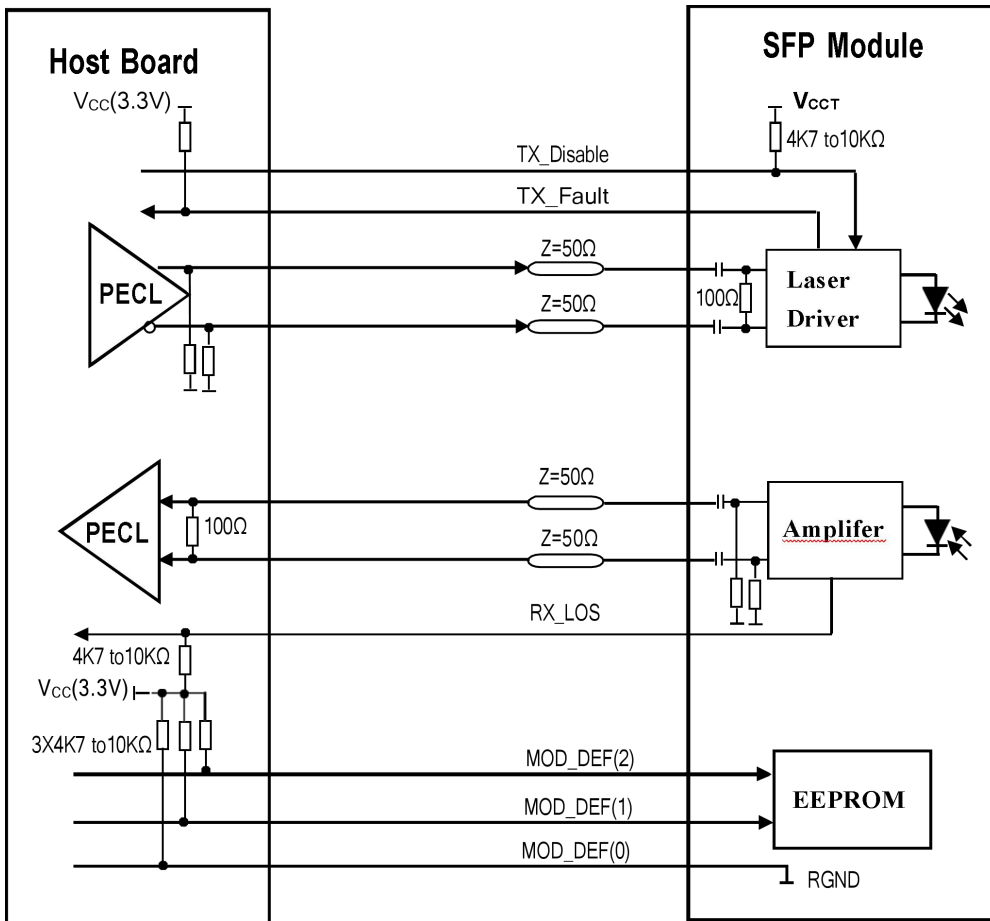

Figure 5. SFP Host Recommended Circuit

### X. Recommended Circuit

Data Address	Length (Byte)	Name of Length	Description and Contents
<b>Base ID Fields</b>			
0	1	Identifier	Type of Serial transceiver (03h=SFP)
1	1	Reserved	Extended identifier of type serial transceiver (04h)
2	1	Connector	Code of optical connector type (07=LC)
3-10	8	Transceiver	SONET & Fiber Channel

Data Address	Length (Byte)	Name of Length	Description and Contents
11	1	Encoding	SONET Scrambled
12	1	BR,Nominal	Nominal baud rate, unit of 100Mbps
13	1	Reserved	(0000h)
14	1	Length(9um,km)	Link length supported for 9/125um fiber, units of km
15	1	Length(9um)	Link length supported for 9/125um fiber, units of 100m
16	1	Length(50um)	Link length supported for 50/125um fiber, units of 10m
17	1	Length(62.5um)	Link length supported for 62.5/125um fiber, units of 10m
18	1	Length(Copper)	Link length supported for copper, units of meters
19	1	Reserved	
20-35	16	VendorName	SFP vendor name:
36	1	Reserved	
37-39	3	VendorOUI	SFP transceiver vendor OUI ID
40-55	16	VendorPN	Part Number: "LonglineXXXXXX" (ASCII)
56-59	4	Vendorrev	Revision level for part number
60-61	2	Wavelength	Laser wavelength
62	1	Reserved	
63	1	CCID	Least significant byte of sum of data in address 0-62
<b>Extended ID Fields</b>			
64-65	2	Option	Indicates which optical SFP signals are implemented(001Ah = LOS, TX_FAULT, TX_DISABLE all supported)

Data Address	Length (Byte)	Name of Length	Description and Contents
66	1	BR,max	Upper bit rate margin, units of %
67	1	BR,min	Lower bit rate margin, units of %
68-83	16	VendorSN	Serial number (ASCII)
84-91	8	Datecode	Manufacturing date code
92	1	DiagnosticType	Diagnostics
93	1	EnhancedOptions	Diagnostics
94	1	SFF-8472	Diagnostics
95	1	CCEX	Check code for the extended ID Fields (addresses 64 to 94)
<b>Vendor Specific ID Fields</b>			
96-127	32	Readable	Vendor specific date, read only

## XI. Diagnostics Memory Contents(A2h)

Data Address	Length (Byte)	Name of Length	Description and Contents
<b>Diagnostic and control/status fields</b>			
0-39	40	A/WThresholds	Diagnostic Flag Alarm and Warning Thresholds
40-55	16	Unallocated	
56-91	16	ExtCalConstants	Diagnostic calibration constants for optional External Calibration
92-94	3	Unallocated	
95	1	CC_DMI	Check code for Base Diagnostic Fields (addresses 0 to 94)

Data Address	Length (Byte)	Name of Length	Description and Contents
96-105	10	Diagnostics	Diagnostic Monitor Data (internally or externally calibrated)
106-109	4	Unallocated	
110	1	Status/Control	Optional Status and Control Bits
111	1	Reserved	Reserved for SFF-8079
112-113	2	AlarmFlags	Diagnostic Alarm Flag Status Bits
114-115	2	Unallocated	
116-117	2	WarningFlags	Diagnostic Warning Flag Status Bits
118-119	2	ExtStatus/Control	Extended module control and status bytes

#### Vendor Specific ID Fields

120-127	8	VendorSpecific	Vendor specific date, read only
128-247	120	UserEEPROM	User writable non-volatile memory
248-255	8	VendorControl	Vendor specific control addresses

## XII. References

1. "Fibre Channel Physical and Signaling Interface (FC-PH, FC-PH2, FC-PH3)". American National Standard for Information Systems.
2. "Fibre Channel Draft Physical Interface Specification (FC-PI 13.0)". American National Standard for Information Systems.
3. Small Form-factor Pluggable (SFP) Transceiver Multi-source Agreement (MSA) September 14, 2000.

### XIII. Mechanical Dimensions

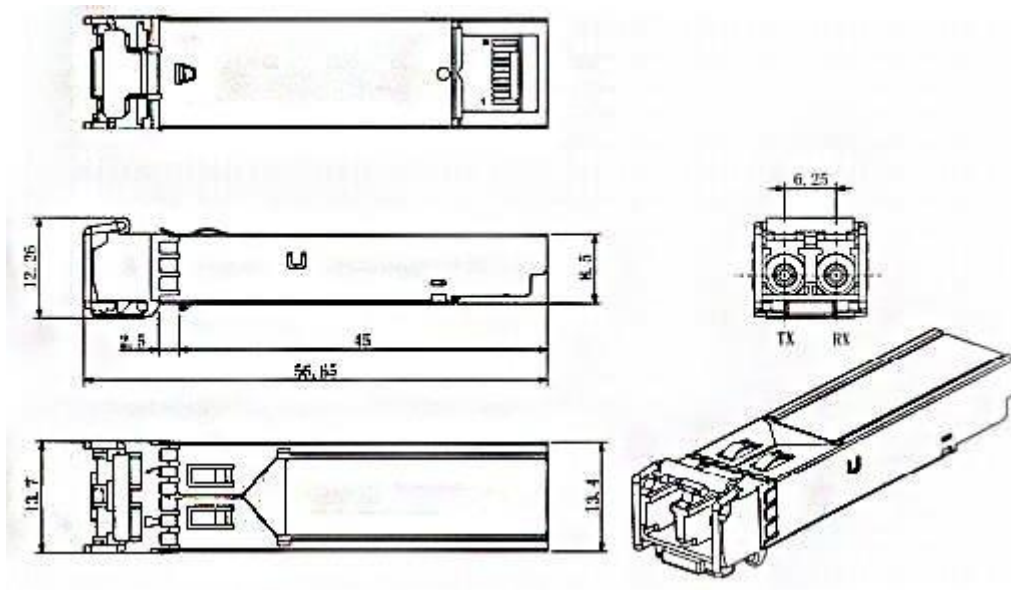

Figure 6. Mechanical Drawing