

25GBASE-ER SFP28 1310nm 40km DOM Transceiver

SFP-25G-ER40-LL



Application

- High-speed storage area networks
- Computer cluster cross-connect
- Custom high-speed data pipes
- Inter Rack Connection

Features

- 25.78Gb/s bit rates
- Hot-Pluggable
- Duplex LC connector
- EML transmitter, APD photo-detector
- Up to 40km on SMF
- Power Supply :+3.3V
- 2-wire interface for management specifications compliant with SFF 8472 digital diagnostic monitoring interface for optical transceivers
- Operating case temperature Range: 0~70° C
- Cost effective SFP28 solution, enables higher port densities and greater bandwidth
- Low Power consumption<1.5W
- RoHS compliant

Description

Longline's SFP28-25GER-31 is a very compact optical transceiver module converts 25Gbit/s serial CML electrical data into serial optical data compliant with the 25GBASE-ER standard. The SFP28 ER module electrical interface is compliant to SFI electrical specifications. The EML transmitter and APD receiver provide superior performance for Ethernet applications at up to 40km links on SMF.

The SFP28 ER Module compliant with SFF-8431, SFF-8432 and IEEE 802.3CC 25GBASE-ER. Digital diagnostics functions are available via a 2-wire serial interface, as specified in SFF-8472.

The fully SFP compliant form factor provides hot pluggability, easy optical port upgrades and low EMI emission.

Product Specifications

I. Absolute Maximum Ratings

Parameter	Symbol	Min	Typ.	Max	Unit	Ref.
Storage Temperature	T _s	-40		+85	°C	
Case Operating Temperature	T _A	0		70	°C	
Maximum Supply Voltage	V _{cc}	0		3.6	V	
Relative Humidity	RH	5		95	%	

II. Electrical Characteristics (T_{OP} = 0 to 70°C, V_{CC} = 3.135 to 3.465 Volts)

Parameter	Symbol	Min	Typ.	Max	Unit	Ref.
Supply Voltage	V _{cc}	3.135		3.465	V	
Supply Current	I _{cc}			450	mA	
Power Consumption	P			1.5	W	
Data Rate	R		25.78		Gb/s	

Transmitter Section:

Input differential impedance	R _{in}		100		Ω	1
-------------------------------------	-----------------	--	-----	--	---	---

Tx Input Single Ended DC Voltage Tolerance (Ref VeeT)	V	-0.3		4	V	
Differential input voltage swing	V _{in,pp}	180		700	mV	2
Transmit Disable Voltage	V _D	2		V _{CC}	V	
Transmit Enable Voltage	V _{EN}	V _{ee}		V _{ee} +0.8	V	
Receiver Section:						
Single Ended Output Voltage Tolerance	V	-0.3		4	V	
Rx Output Diff Voltage	V _o	150		900	mV	
Rx Output Rise and Fall Time	T _r /T _f	9.5			ps	3
LOS Fault	V _{LOS fault}	2		V _{CCHOST}	V	4
LOS Normal	V _{LOS norm}	V _{ee}		V _{ee} +0.8	V	4

Notes:

- 1.Connected directly to TX data input pins. AC coupling from pins into laser driver IC.
- 2.Per SFF-8431 Rev 3.0
- 3.20%~80%
- 4.LOS is an open collector output. Should be pulled up with 4.7k – 10kΩ on the host board. Normal operation is logic 0; loss of signal is logic 1. Maximum pull-up voltage is 5.5V.

III. Optical Characteristics (TOP = 0 to 70°C, VCC = 3.135 to 3.465 Volts)

Parameter	Symbol	Min	Typ.	Max	Unit	Ref.
Transmitter Section:						
Center Wavelength	λ _t	1295		1310	nm	
spectral width	Δλ			1	nm	
Average Optical Power	P _{avg}	0		+6	dBm	1

Laser Off Power	P _{off}			-30		dBm
Extinction Ratio	ER	4				dB
Receiver Section:						
Center Wavelength	λ_r	1295		1325		nm
Receiver Sensitivity(OMA)	Sen			-19		dBm 2
Stressed Sensitivity(OMA)	Sen ₂			-16.5		dBm 2
Los Assert	LOS _A	-30				dBm
Los Dessert	LOS _D			-11		dBm
Los Hysteresis	LOS _H	0.5		5		dB
Overload	Sat	-9				dBm 3
Receiver Reflectance	R _{rx}			-12		dB

Notes:

1. Average power figures are informative only, per IEEE802.3CC.
2. Conditions of stressed receiver tests per IEEE802.3CC. At 5E-5 BER.
3. Receiver overload specified in OMA and under the worst comprehensive stressed condition.

IV. Timing Characteristics

Parameter	Symbol	Min	Typ.	Max	Unit
TX_Disable Assert Time	t _{off}			100	us
TX_Disable Negate Time	t _{on}			2	ms
Time to Initialize Include Reset of TX_FAULT	t _{int}			300	ms
TX_FAULT from Fault to Assertion	t _{fault}			1	ms

TX_Disable Time to Start Reset	t_reset	10	us
Receiver Loss of Signal Assert Time	T _A ,RX_LOS	100	us
Receiver Loss of Signal Deassert Time	T _d ,RX_LOS	100	us
Rate-Select Chage Time	t_ratesel	10	us
Serial ID Clock Time	t_serial-clock	100	kHz

V. Digital Diagnostic Monitoring Information

Data Address	Parameter	Accuracy	Unit
96-97	Transceiver Internal Temperature	± 3.0	°C
98-99	VCC3 Internal Supply Voltage	± 3.0	%
100-101	Laser Bias Current	± 10	%
102-103	Tx Output Power	± 2.0	dBm
104-105	Rx Input Power	± 2.0	dBm

VI. Pin Assignment

Pin	Symbol	Description	Notes
1	VeeT	Module transmitter ground	1
2	Tx Fault	Module transmitter fault	2
3	Tx Disable	Transmitter Disable; Turns off transmitter laser output	3
4	SDL	2 wire serial interface data input/output (SDA)	4
5	SCL	2 wire serial interface clock input (SCL)	4
6	MOD-ABS	Module Absent, connect to VeeR or VeeT in the module	2
7	RS0	Rate select0, optionally control SFP+ receiver. When high, input data rate >4.5Gb/ s; when low, input data rate <=4.5Gb/s	

8	LOS	Receiver Loss of Signal Indication	
9	RS1	Rate select0, optionally control SFP+ transmitter. When high, input data rate >4.5Gb/s; when low, input data rate <=4.5Gb/s	
10	VeeR	Module receiver ground	1
11	VeeR	Module receiver ground	1
12	RD-	Receiver inverted data out put	
13	RD+	Receiver non-inverted data out put	
14	VeeR	Module receiver ground	1
15	VccR	Module receiver 3.3V supply	
16	VccT	Module transmitter 3.3V supply	
17	VeeT	Module transmitter ground	1
18	TD+	Transmitter non-inverted data out put	
19	TD-	Transmitter inverted data out put	
20	VeeT	Module transmitter ground	1

Notes:

- 1.The module ground pins shall be isolated from the module case.
- 2.This pin is an open collector/drain output pin and shall be pulled up with 4.7K-10Kohms to Host_Vcc on the host board.
- 3.This pin shall be pulled up with 4.7K-10Kohms to VccT in the module.
- 4.This pin is an open collector/drain output pin and shall be pulled up with 4.7K-10Kohms to Host_Vcc on the host board.

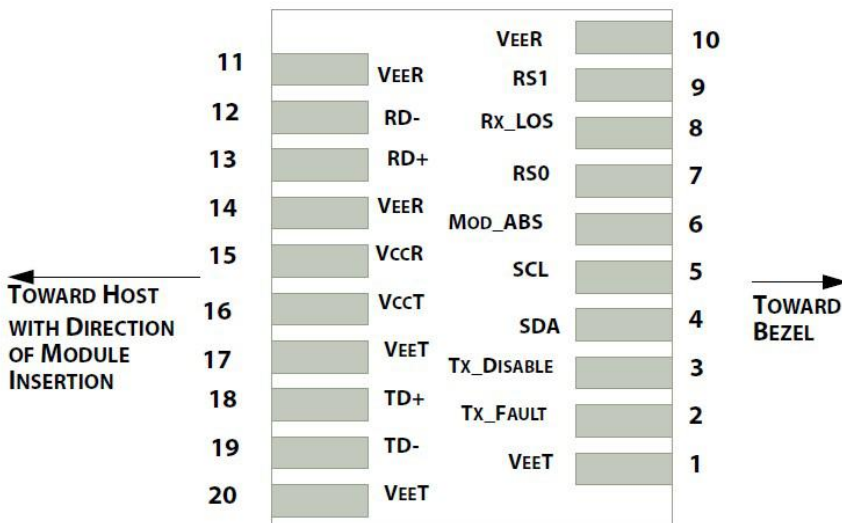

Diagram of Host Board Connector Block Pin Numbers and Name

VII. SFP Module EEPROM Information and Management

The SFP modules implement the 2-wire serial communication protocol as defined in the SFF-8472. The serial ID information of the SFP modules and Digital Diagnostic Monitor parameters can be accessed through the I²C interface at address A0h and A2h.

The memory is mapped in Table 1.

Detailed ID information (A0h) is listed in Table 2.

And the DDM specification at address A2h.

For more details of the memory map and byte definitions, please refer to the SFF-8472, "Digital Diagnostic Monitoring Interface for Optical Transceivers". The DDM parameters have been internally calibrated.

Digital Diagnostic Memory Map (Specific Data Field Descriptions)

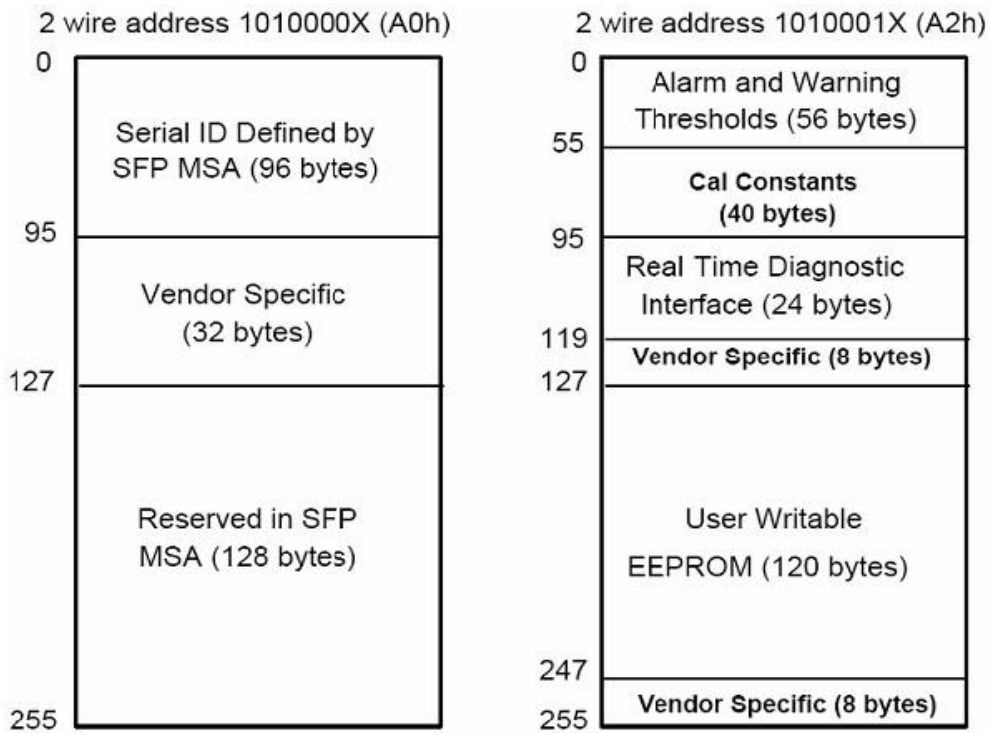

EEPROM Serial ID Memory Contents (A0h)

Data Address	Length (Byte)	Name of Length	Description and Contents
Base ID Fields			
0	1	Identifier	Type of Serial transceiver (03h=SFP)
1	1	Reserved	Extended identifier of type serial transceiver (04h)
2	1	Connector	Code of optical connector type (07=LC)
3-10	8	Transceiver	25G Base-ER

11	1	Encoding	64B/66B
12	1	BR, Nominal	Nominal baud rate, unit of 100Mbps
13-14	2	Reserved	(0000h)
15	1	Length(9um)	Link length supported for 9/125um fiber, units of 100m
16	1	Length(50um)	Link length supported for 50/125um fiber, units of 10m
17	1	Length(62.5um)	Link length supported for 62.5/125um fiber, units of 10m
18	1	Length(Copper)	Link length supported for copper, units of meters
19	1	Reserved	
20-35	16	Vendor Name	SFP vendor name: Longline
36	1	Reserved	
37-39	3	Vendor OUI	SFP transceiver vendor OUI ID
40-55	16	Vendor PN	Part Number: "SFP28-25GER-31" (ASCII)
56-59	4	Vendor rev	Revision level for part number
60-62	3	Reserved	
63	1	CCID	Least significant byte of sum of data in address 0-62

Extended ID Fields

64-65	2	Option	Indicates which optical SFP signals are implemented (001Ah = LOS, TX_FAULT, TX_DISABLE all supported)
66	1	BR, max	Upper bit rate margin, units of %
67	1	BR, min	Lower bit rate margin, units of %
68-83	16	Vendor SN	Serial number (ASCII)
84-91	8	Date code	Longline's Manufacturing date code
92-94	3	Reserved	
95	1	CCEX	Check code for the extended ID Fields (addresses 64 to 94)

Vendor Specific ID Fields

96-127	32	Readable	Longline specific date, read only
128-255	128	Reserved	Reserved for SFF-8079

VIII. Regulatory Compliance

The SFP28-25GER-31 complies with international Electromagnetic Compatibility (EMC) and international safety requirements and standards (see details in Table following).

Electrostatic Discharge (ESD) to the Electrical Pins	MIL-STD-883E Method 3015.7	Class 1(>1000 V)
Electrostatic Discharge (ESD) to the Duplex LC Receptacle	IEC 61000-4-2 GR-1089-CORE	Compatible with standards
Electromagnetic Interference (EMI)	FCC Part 15 Class B EN55022 Class B (CISPR 22B) VCCI Class B	Compatible with standards
Laser Eye Safety	FDA 21CFR 1040.10 and 1040.11 EN60950, EN (IEC) 60825-1,2	Compatible with Class 1 laser product.

IX. Recommended Circuit

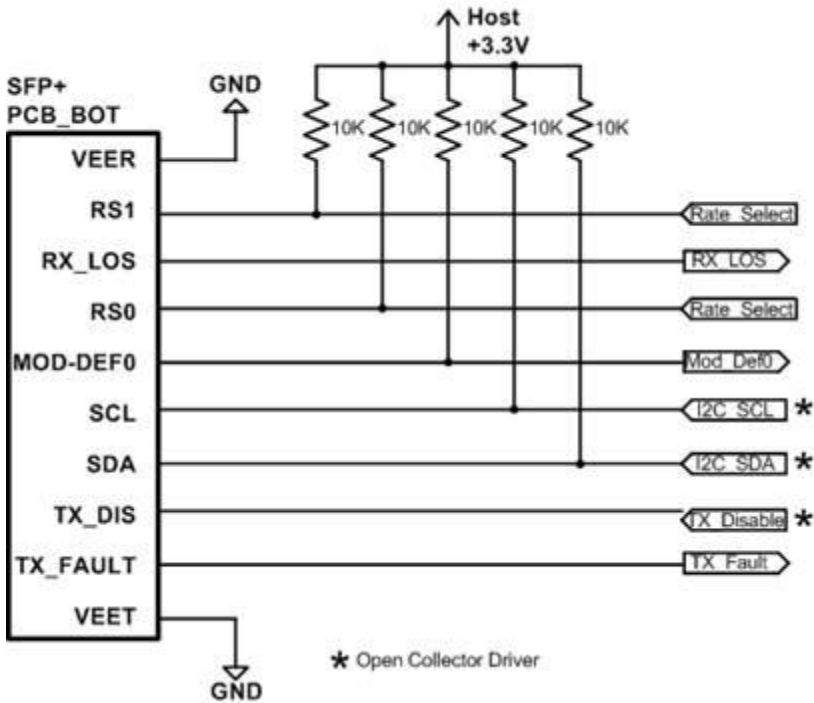
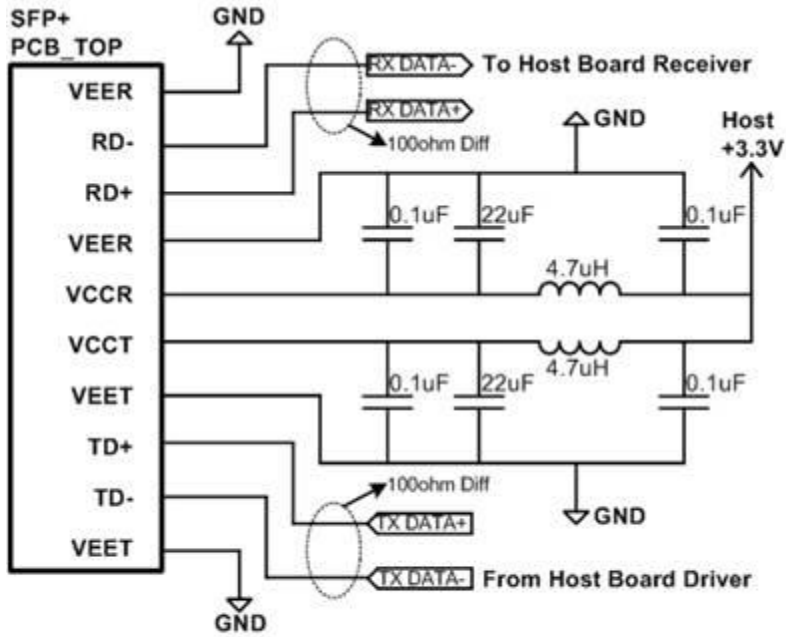

Recommended High - speed Interface Circuit

X. Transceiver Block Diagram

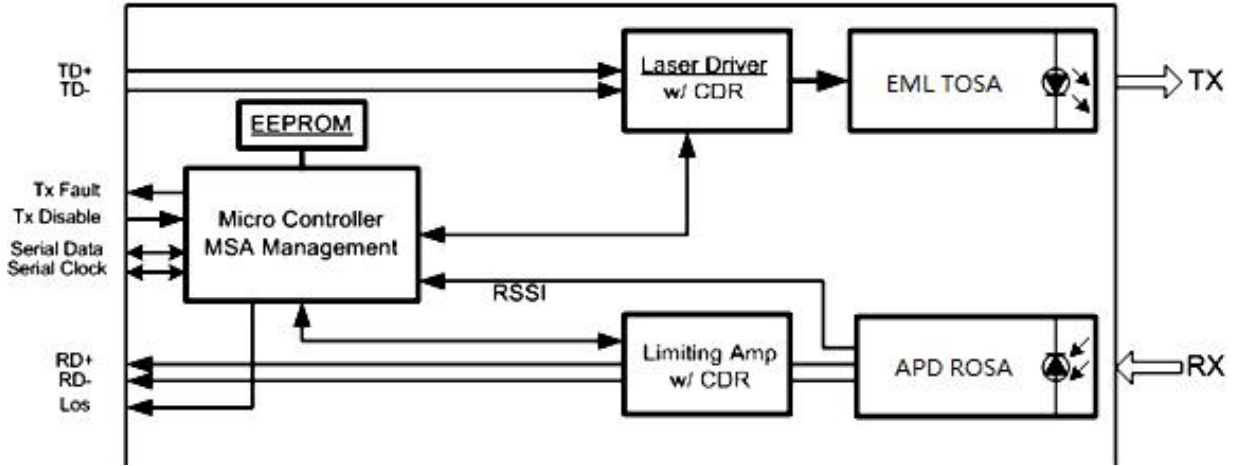

XI. Mechanical Dimensions

