

25GBASE-ER SFP28 1310nm 30km DOM Transceiver

SFP-25G-ER-LL

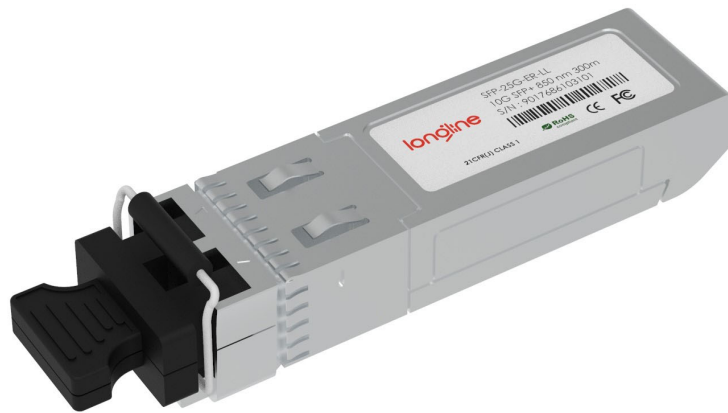

Application

- High-speed storage area networks
- CPRI 10

Features

- UP to 25.78Gb/s data links
- Hot-Pluggable SFP28 footprint
- Duplex LC connector
- DML laser transmitter, APD photo-detector
- Up to 30km on SMF without FEC
- Single 3.3V power supply
- Operating case temperature range: 0~ 70° C
- RoHS compliant
- 2-wire interface for management specifications compliant with SFF 8472 digital diagnostic monitoring interface for optical transceivers

Description

SFP28 transceivers are designed for use in Ethernet links up to 25.78 Gb/s data rate and up to 30km (without FEC) link length.

They are compliant SFF-8472, and compatible with SFF-8432 and applicable portions of SFF-8431. The product is RoHS compliant and lead-free per Directive 2011/96/EU.

Product Specifications

I. Absolute Maximum Ratings

Parameter	Symbol	Min	Typ.	Max	Unit
Storage Temperature	T_S	-40		85	°C
Case Operating Temperature	T_A	0		70	°C
Maximum Supply Voltage	V_{CC}	0		3.6	V
Relative Humidity	RH	0		85	%

II. Electrical Characteristics (TOP= 0 to 70 ° C, VCC = 3.15 to 3.46 Volts)

Parameter	Symbol	Min	Typ.	Max	Unit	Note
Supply Voltage	V_{CC}	3.15		3.46	V	
Supply Current	I_{CC}			450	mA	
Power Consumption	P			1.5	W	
Data Rate	R	-	25.8		Gb/s	

Parameter	Symbol	Min	Typ.	Max	Unit	Note
Transmitter						
Input Differential impedance	R_{in}		100		Ω	1
Differential input Voltage Swing	$V_{in,pp}$	180		700	mV	2
Transmit Disable Voltage	V_D	2		V_{cc}	V	3
Transmit Enable Voltage	V_{EN}	V_{ee}		$V_{ee}+0.8$	V	
Receiver						
Single Ended Output Voltage Tolerance	V	-0.3		4	V	
Rx Output Diff Voltage	V_o	185		800	mV	
LOS Fault	$V_{LOS\ fault}$	2		V_{cc_HOST}	V	4
LOS Normal	$V_{LOS\ norm}$	V_{ee}		$V_{ee}+0.8$	V	4

Notes:

1. Connected directly to TX data input pins. AC coupling from pins into laser driver IC.
2. Per SFF-8431 Rev 3.0
3. Into 100 ohms differential termination.
4. LOS is an open collector output. Should be pulled up with 4.7k – 10k Ω on the host board. Normal operation is logic 0; loss of signal is logic 1. Maximum pull-up voltage is 5.5V.

III. Optical Characteristics (TOP = 0 to 70° C, VCC = 3.15 to 3.46 Volts)

Parameter	Symbol	Min	Typ.	Max	Unit	Note
Transmitter						
Center Wavelength	λ_t	1295		1325	nm	
Spectral Width	$\Delta\lambda$			1	nm	
Average Optical Power	P_{avg}	0		+6	dBm	1
Laser Off Power	P_{off}			-30	dBm	
Side Mode Suppression Ratio		30				
Extinction Ratio	ER	4			dB	
Optical Return Loss Tolerance				-12	dB	
Receiver						
Center Wavelength	λ_r	1260		1370	nm	
Receiver Sensitivity	S_{en}			-19	dBm	2
Los Assert	LOS_A	-30			dBm	
Los Dessert	LOS_D			-19	dBm	
Los Hysteresis	LOS_H	0.5			dB	
Overload		-6			dBm	

Notes:

1. Average power figures are informative only, per IEEE802.3CC.

2. Receiver sensitivity is informative. Shall be measured with conformance test signal for . BER = 5×10^{-5} .

IV. Timing Characteristics

Parameter	Symbol	Min	Typ.	Max	Units
TX_Disable Assert Time	t_{off}			100	us
TX_Disable Negate Time	t_{on}			2	ms
Time to Initialize 2-wire interface	$t_{2w_start_up}$			300	ms
Time to Initialize	t_{start_up}			300	ms
Time to Initialize cooled module and time to power up a cooled module to Power level II	$t_{start_up_cooled}$			90	s
Time to Power Up to Level II	t_{power_level2}			300	ms
Time to Power Down from Level II	t_{power_down}			300	ms
Tx_Fault assert	Tx_Fault_on			1	ms
Tx_Fault assert for cooled module	$Tx_Fault_on_cooled$			50	ms
TX_FAULT Reset	t_{reset}	10			us
Rx_LOS assert delay	t_{los_on}			100	us
Rx_LOS negate delay	t_{los_off}			100	us

V. Digital Diagnostic Specifications

Parameter	Symbol	Max	Min	Accuracy	Unit
Transceiver Temperature	DDDTemp	0	+70	±3.0°C	°C
Transceiver Supply Voltage	DDDVoltage	3.15	3.45	±3.0%	V
Transceiver Bias Current	DDDBias	0	35	±10%	mA
Transceiver Output Power	DDDTx-Power	-5	+5	±2dB	dBm
Receiver Average Optical Input Power	DDDRx-Power	-16	-3	±2dB	dBm

VI. Pin Description

Pin	Symbol	Name/Description	Ref.
1	VeeT	Module transmitter ground	1
2	Tx Fault	Module transmitter fault	2
3	Tx Disable	Transmitter Disable; Turns off transmitter laser output	3
4	SDL	2 wire serial interface data input/output (SDA)	4
5	SCL	2 wire serial interface clock input (SCL)	4
6	MOD-ABS	Module Absent, connect to VeeR or VeeT in the module	2
7	RS0	Rate select0: module inputs and are pulled low to VeeT with > 30 kΩ resistors in the module.	
8	LOS	Receiver Loss of Signal Indication	
9	RS1	Rate select1: module inputs and are pulled low to VeeT with > 30 kΩ resistors in the module.	
10	VeeR	Module receiver ground	1

11	VeeR	Module receiver ground	1
12	RD-	Receiver inverted data out put	
13	RD+	Receiver non-inverted data out put	
14	VeeR	Module receiver ground	1
15	VccR	Module receiver 3.3V supply	
16	VccT	Module transmitter 3.3V supply	
17	VeeT	Module transmitter ground	1
18	TD+	Transmitter non-inverted data out put	
19	TD-	Transmitter inverted data out put	
20	VeeT	Module transmitter ground	1

Notes:

- 1.The module ground pins shall be isolated from the module case.
- 2.This pin is an open collector/drain output pin and shall be pulled up with 4.7K-10Kohms to Host_Vcc on the host board.
- 3.This pin shall be pulled up with 4.7K-10Kohms to VccT in the module.
- 4.This pin is an open collector/drain output pin and shall be pulled up with 4.7K-10Kohms to Host_Vcc on the host board.

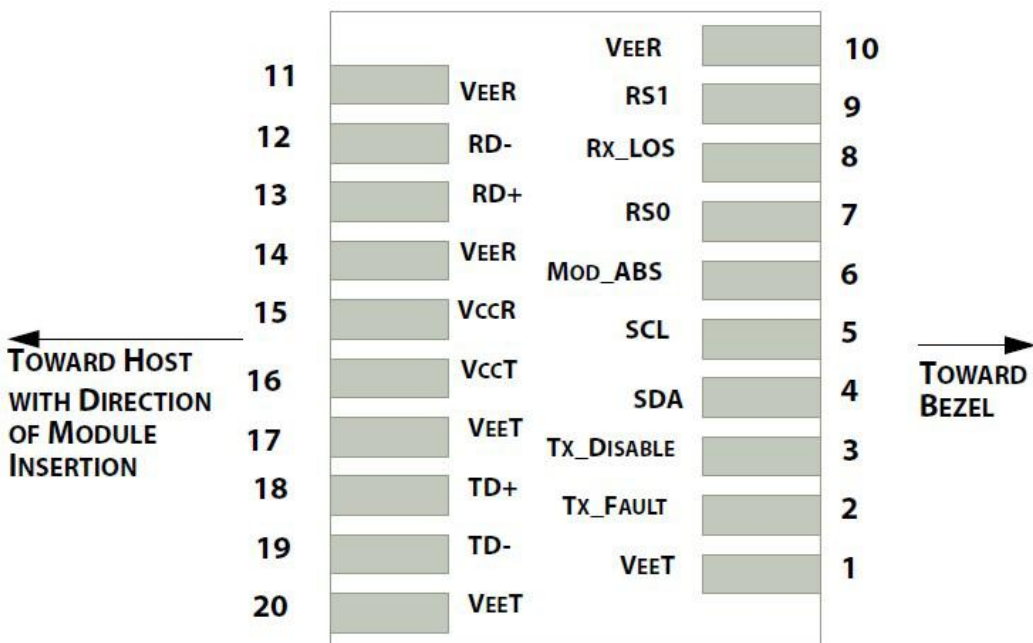
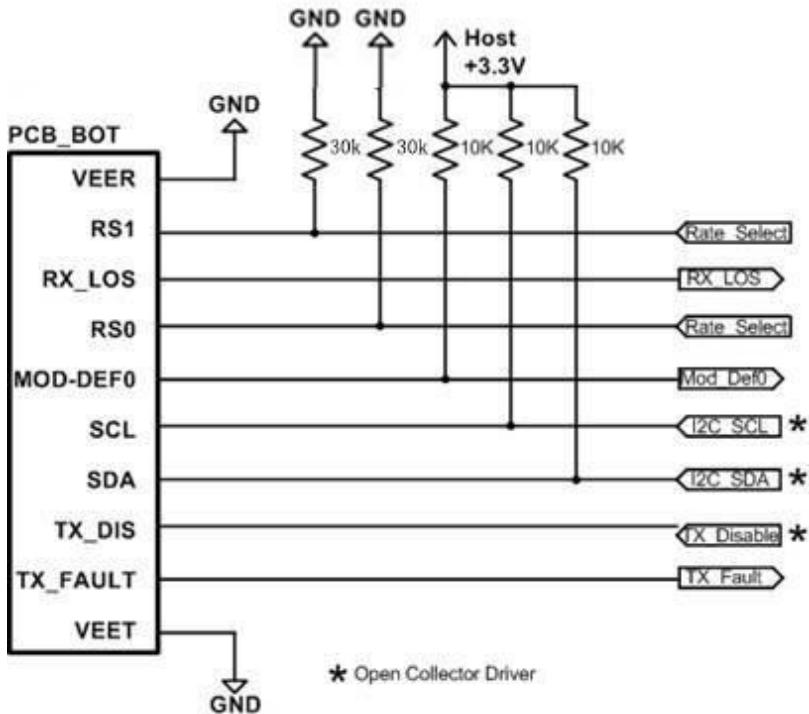
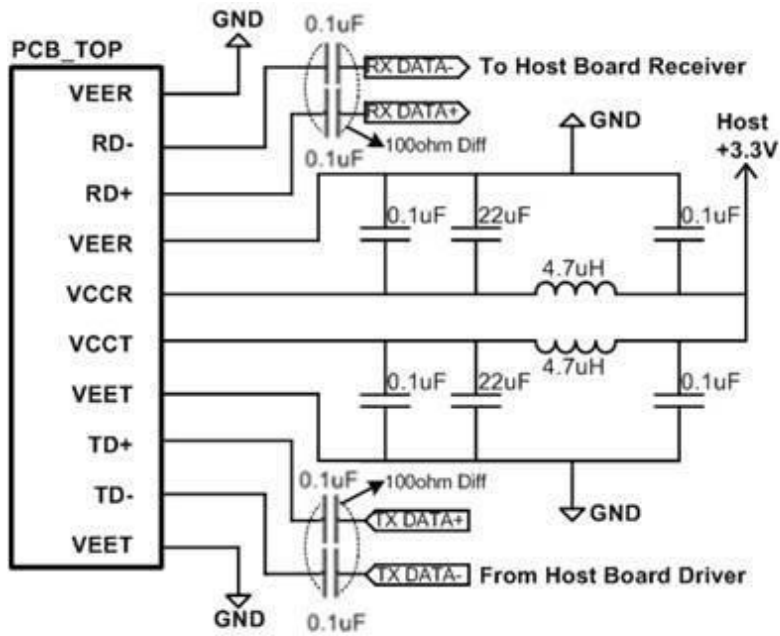

Diagram of Host Board Connector Block Pin Numbers and Names

VII .Recommended Circuit:



Recommended High-speed Interface Circuit

VIII. Transceiver Block Diagram

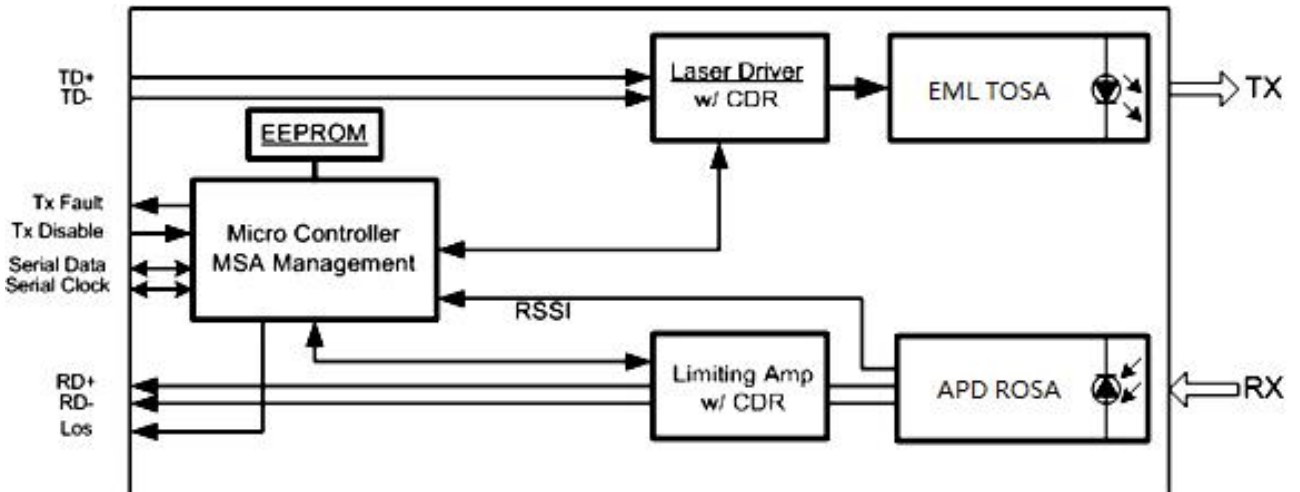

IX. Mechanical Dimensions

