

10GBASE-ZR SFP+ 1550nm 80km Industrial DOM Duplex LC Transceiver

SFP-10G-ZR-I-LL



Application

- 10GBASE-LR at 10.3Gbps
- 10GBASE-LW at 9.95Gbps
- Other Optical Links

Standards

- SFF-8402
- SFF-8432
- SFF-8472
- SFF-8024
- SFF-8431
- IEEE Std 802.3by

Features

- Operating Data Rate up to 10.31Gbps
- High Sensitivity APD Receiver
- Single 3.3V Power Supply and TTL Logic Interface
- 1550nm EML Transmitter
- Low Power Consumption < 2W
- Hot-Pluggable Duplex LC Connector Interface
- Industrial Temperature Range : -40°C to 85°C
- 2-wire Interface with Integrated Digital Diagnostic Monitoring

IV. Pin Definitions

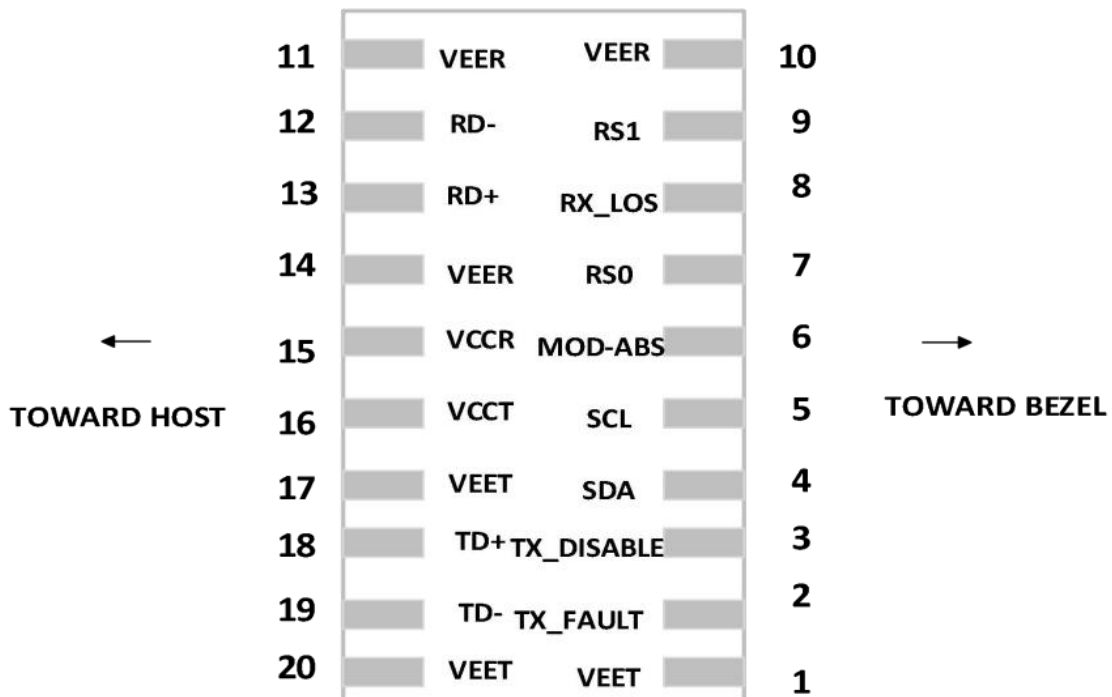

V. Pin Descriptions

Pin	Name	Function	Plug Seq.	Notes
1	V_{EET}	Transmitter Ground	1	5)
2	TX Fault	Transmitter Fault Indication	3	1)
3	TX Disable	Transmitter Disable	3	2) Module disables on high or open
4	SDA	Transmitter Disable	3	3) 2 wire serial ID interface.
5	SCL	Module Definition 2	3	3) 2 wire serial ID interface.
6	MOD-ABS	Module Definition 1	3	3)

Description

The 10Gigabit SFP+ Transceiver based on uncooled DFB Laser is designed to transmit and receive serial optical data links up from 1Gb/s to 11.3 Gb/s data rate over single mode optical fiber with 80km.

The transceiver is compliant with SFF-8431,SFF-8432, 10GFC Rev 4.0, and 10GBASE-ZR. Digital diagnostics functions are available via a 2-wire serial interface, as specified in SFF-8472.

Product Specifications

I. Absolute Maximum Ratings

Parameter	Symbol	Min.	Max.	Unit
Storage Temperature	T_s	-40	+85	°C
Maximum Supply Voltage	V_{CC}	-0.5	3.6	V
Operating Relative Humidity	RH		95	%

Notes:

1. Exceeding any one of these values may destroy the device immediatel.

II. Electrical Characteristics

Parameter	Symbol	Min.	Typ.	Max.	Unit	Notes
Transmitter						
CML Inputs (Differential)	V_{IN}	150		1200	mVpp	AC Coupled Inputs
Input AC Common Mode Voltage		0		25	mV	RMS
Input Impedance (Differential)	Z_{IN}	85	100	115	ohms	$R_{IN} > 100\text{kohms@DC}$
TX_DIS	High	2		V_{CC}	V	
	Low	0		0.8		

Parameter	Symbol	Min.	Typ.	Max.	Unit	Notes
TX_FAULT	High	2		$V_{CC}+0.3$	V	Lo = 400 μ A; Host V_{CC}
	Low	0		0.5		Lo= -4.0 mA

Receiver

CML Outputs (Differential)	Vout	350		700	mVpp	AC Coupled Outputs
Output Impedance (Differential)	Zout	85	100	115	ohms	

RX_LOS	High	2		$V_{CC}+0.3$		Lo = 400 μ A; Host V_{CC}
	Low	0		0.8		Lo= -4.0mA
MOD_DEF (0.2)	VoH	2.5			V	With Serial ID
	VoL	0		0.5		

III. Optical Characteristics

Parameter	Symbol	Min.	Typ.	Max.	Unit
Power Budget		23			dB
Data Rate		0.6	10.3125		Gbps
Transmitter					
Center Wavelength	λ_C	1528	1550	1565	nm

Parameter	Symbol	Min.	Typ.	Max.	Unit
Spectral Width (RMS)	$\Delta\lambda$			1	nm
Average Output Power* (Note1)	P_{OUT}	0		5	dBm
Extinction Ratio	ER	7.5			dB
Average Power of OFF Transmitter	P_{OFF}			-30	dBm
Relative Intensity Noise	R_{IN}			-128	dB/Hz
Side Mode Suppression Ratio	SMSR	30			dB
Transmitter Dispersion Penalty	TDP			3	dB
TX_Disable Assert Time	T_{off}			10	us
Receiver					
Center Wavelength	λ_C	1260	1550	1600	nm
Receiver Sensitivity* (Note2)	P_{MIN}			-23	dBm
Receiver Overload	P_{MAX}	-8			dBm
LOS De-Assert	LOS_D			-26	dBm
LOS Assert	LOS_A	-38			dBm
LOS-Hysteresis	P_{HYS}	0.5			dB

Notes:

- Output is coupled into a 9/125um SMF.
- Measured with worst ER, BER less than 1E-12 and PRBS 2^31-1 at 10.3125Gbps.

Pin	Name	Function	Plug Seq.	Notes
7	RS0	RX Rate Select (LVTTTL)	3	Rate Select 0, optionally controls SFP+ module receiver. This pin is pulled low to V_{EET} with a $> 30K$ resistor..
8	LOS	Loss of Signal	3	4)
9	RS1	TX Rate Select (LVTTTL)	1	Rate Select 1, optionally controls SFP+ Module transmitter. This pin is pulled low to V_{EET} with a $>30K$ resistor.
10	V_{EER}	Receiver Ground	1	5)
11	V_{EER}	Receiver Ground	1	5)
12	RD-	Inv. Received Data Out	3	6)
13	RD+	Received Data Out	3	6)
14	V_{EER}	Receiver Ground	1	5)
15	V_{CCR}	Receiver Power	2	7) $3.3V \pm 5\%$
16	V_{CCT}	Transmitter Power	2	7) $3.3V \pm 5\%$
17	V_{EET}	Transmitter Ground	1	5)
18	TD+	Transmit Data In	3	8)
19	TD-	Inv. Transmit Data In	3	8)
20	V_{EET}	Transmitter Ground	1	5)

Notes:

1. TX Fault is an open collector/drain output, which should be pulled up with a 4.7K-10K resistor on the host board. Pull up voltage between 2.0V and V_{CCR} R+0.3V. When high, output indicates a laser fault of some kind. Low indicates normal operation. In the low state, the output will be pulled to $<0.8V$.

2. TX Disable is an input that is used to shut down the transmitter optical output. It is pulled up within the module with a 4.7-10K resistor. It states are Low (0-0.8V): Transmitter on. (>0.8 , $<2.0V$): Undefined High (2.0–3.465V): Transmitter Disabled Open: Transmitter Disabled.

3. Modulation Absent, connected to V_{EET} or V_{EER} in the module.
4. LOS (Loss of Signal) is an open collector/drain output, which should be pulled up with a 4.7K-10K resistor. Pull up voltage between 2.0V and $V_{CC1} + 0.3V$. When high, this output indicates the received optical power is below the worst-case receiver sensitivity (as defined by the standard in use). Low indicates normal operation.
5. V_{EER} and V_{EET} may be internally connected within the SFP module.
6. RD-/+: These are the differential receiver outputs. They are AC coupled 100 differential lines which should be terminated with 100 (differential) at the user SERDES. The AC coupling is done inside the module and is thus not required on the host board. The voltage swing on these lines will be between 400 and 2000mV differential (200-1000mV single ended) when properly terminated.
7. V_{CCR} and V_{CCT} are the receiver and transmitter power supplies. They are defined as $3.3V \pm 5\%$ at the SFP connector pin. Maximum supply current is 300mA. Recommended host board power supply filtering is shown below. Inductors with DC resistance of less than 1 ohm should be used in order to maintain the required voltage at the SFP input pin with 3.3V supply voltage when the recommended supply-filtering network is used, hot plugging of the SFP transceiver module will result in an inrush current of no more than 30mA greater than the steady state value. V_{CCR} and V_{CCT} may be internally connected within the SFP transceiver module.
8. TD-/+: These are the differential transmitter inputs. They are AC-coupled, differential lines with 100 differential termination inside the module.

VI. Digital Diagnostic Specifications

Parameter	Range	Unit	Accuracy	Calibration
Temperature	-40 to +85	°C	$\pm 3^\circ\text{C}$	Internal / External
Voltage	3.0 to 3.6	V	$\pm 3\%$	Internal / External
Bias Current	30 to 120	mA	$\pm 10\%$	Internal / External
TX Power	0 to +5	dBm	$\pm 3\text{dB}$	Internal / External
RX Power	-23 to -8	dBm	$\pm 3\text{dB}$	Internal / External

10G SFP+ transceivers provide an enhanced digital diagnostic.

VII. DDM Threshold

DDM	Temperature (°C)	V _{CC} (V)	I _{bias} (mA)	Tx Power (dBm)	Rx Power (dBm)
High Alarm	95	3.6	120	7	-6
High Warning	85	3.5	100	5	-8
Low Warning	-40	3.1	30	0	-23
Low Alarm	-50	3	20	-2	-25

Notes:

The transceivers provide serial ID memory contents and diagnostic information about the present operating conditions by the 2-wire serial interface (SCL, SDA). The diagnostic information with internal calibration or external calibration all are implemented, including received power monitoring, transmitted power monitoring, bias current monitoring, supply voltage monitoring and temperature monitoring.

VIII. Mechanical Specifications

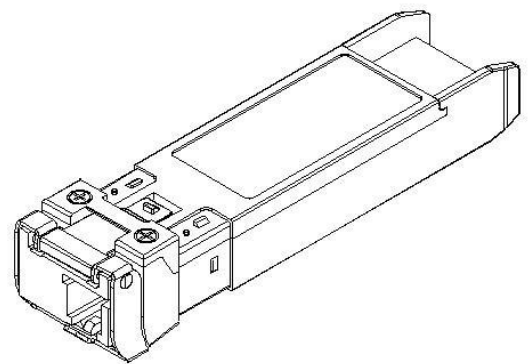
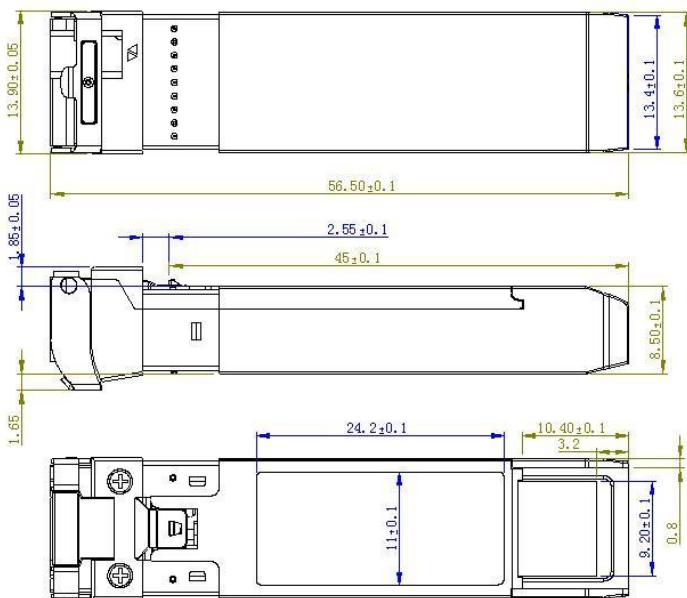

Unit: mm

Unspecified Tolerance: ±0.2mm