

25G CWDM SFP28 1270-1370nm 30km DOM Transceiver

JD102B-LL



Application

- High-speed storage area networks
- CPRI 10

Features

- UP to 25.78Gb/s data links
- Hot-Pluggable SFP28 footprint
- Duplex LC connector
- DML laser transmitter, APD photo-detector
- Up to 30km on SMF without FEC
- Up to 40km on SMF with FEC
- 2-wire interface for management specifications compliant with SFF 8472 digital diagnostic monitoring interface for optical transceiver
- Power Supply :+3.3V
- Operating case temperature Range: 0~ 70° C
- RoHS Compliant

Description

Longline's SFP28 transceivers are designed for use in Ethernet links up to 25.78 Gb/s data rate and up to 30km (without FEC) 40KM (with FEC) link length. They are compliant SFF-8472, and compatible with SFF-8432 and applicable portions of SFF-8431. The product is RoHS compliant and lead-free per Directive 2011/96/EU.

Product Specifications

I. Absolute Maximum Ratings

Parameter	Symbol	Min	Typ.	Max	Unit	Ref.
Storage Temperature	T_S	-40		+85	°C	
Case Operating Temperature	T_A	0		+70	°C	
Maximum Supply Voltage	V_{CC}	0		3.6	V	
Relative Humidity (Non-condensing)	RH	0		85	%	

II. Electrical Characteristics ($T_{OP} = 0$ to $70^{\circ}C$, $V_{CC} = 3.15$ to 3.46 Volts)

Parameter	Symbol	Min	Typ.	Max	Unit	Ref.
Supply Voltage	V_{CC}	3.15		3.46	V	
Supply Current	I_{CC}			450	mA	
Power Consumption	P			1.5	W	
Data Rate	R		25.8		Gb/s	

Transmitter Section:

Input differential impedance	R_{in}		100		Ω	1
Differential input voltage swing	$V_{in,pp}$	180		700	mV	2
Transmit Disable Voltage	V_D	2		V_{CC}	V	3

Transmit Enable Voltage	V_{EN}	Vee	Vee+0.8	V	
Receiver Section:					
Single Ended Output Voltage Tolerance	V	-0.3	4	V	
Rx Output Diff Voltage	V_o	185	800	mV	
LOS Fault	$V_{LOS\ fault}$	2	V_{CCHOST}	V	4
LOS Normal	$V_{LOS\ norm}$	Vee	$V_{EE}+0.8$	V	4

Notes:

- 1.Connected directly to TX data input pins. AC coupling from pins into laser driver IC.
- 2.Per SFF-8431 Rev 3.0
- 3.Into 100 ohms differential termination.
- 4.LOS is an open collector output. Should be pulled up with 4.7k – 10k Ω on the host board. Normal operation is logic 0; loss of signal is logic 1. Maximum pull-up voltage is 5.5V.

III. Optical Characteristics ($T_{OP}=0$ to $70^{\circ}C$, $V_{CC}= 3.15$ to 3.46 Volts)

Parameter	Symbol	Min	Typ.	Max	Unit	Ref.
Transmitter Section:						
Center Wavelength	λ_t	$\lambda-6.5$	λ	$\lambda+6.5$	nm	
spectral width(-20dB)	$\Delta\lambda$			1	nm	
Average Optical Power	P_{avg}	0		+6	dBm	1
Laser Off Power	P_{off}			-30	dBm	
Side Mode Suppression Ratio		30				
Extinction Ratio	ER	4			dB	
Optical Return Loss Tolerance				-12	dB	

Receiver Section:

Center Wavelength	λ_r	1260	1370	nm	
Receiver Sensitivity	Sen		-19	dBm	2
Los Assert	LOS _A	-30		dBm	
Los Dessert	LOS _D		-19	dBm	
Los Hysteresis	LOS _H	0.5		dB	
Overload		-6		dBm	

Notes:

1. Average power figures are informative only, per IEEE802.3cc.

2. Receiver sensitivity is informative. Shall be measured with conformance test signal for . BER = 5×10^{-5} .

IV. Timing Characteristics

Parameter	Symbol	Min	Typ.	Max	Unit	Ref.
TX_Disable Assert Time	t _{off}			100	us	
TX_Disable Negate Time	t _{on}			2	ms	
Time to Initialize 2-wire interface	t _{2w_start_up}			300	ms	
Time to Initialize	t _{2w_start_up}			300	ms	
Time to Initialize cooled module and time to power up a cooled module to Power level II	t _{start_up_cooled}			90	s	
Time to Power Up to Level II	t _{power_level2}			300	ms	
Time to Power Down from Level II	t _{power_down}			300	ms	
Tx_Fault assert	Tx_Fault_on			1	ms	
Tx_Fault assert for cooled module	Tx_Fault_on_cooled			50	ms	
TX_FAULT Reset	t _{reset}	10			us	

Rx_LOS assert delay	t_los_on			100	us	
Rx_LOS negate delay	t_los_off			100	us	

V. Digital Diagnostics Specifications

Parameter	Symbol	Units	Min	Max	Accuracy
Transceiver Temperature	DDDTemp	°C	0	+70	± 3°C
Transceiver Supply Voltage	DDDVoltage	V	3.15	3.45	± 3%
Transmitter Bias Current	DDDBias	mA	0	35	± 10%
Transmitter Output Power	DDDTx-Power	dBm	-5	+5	± 2dB
Receiver Average Optical Input Power	DDDRx-Power	dBm	-16	-3	± 2dB

VI. Pin Description

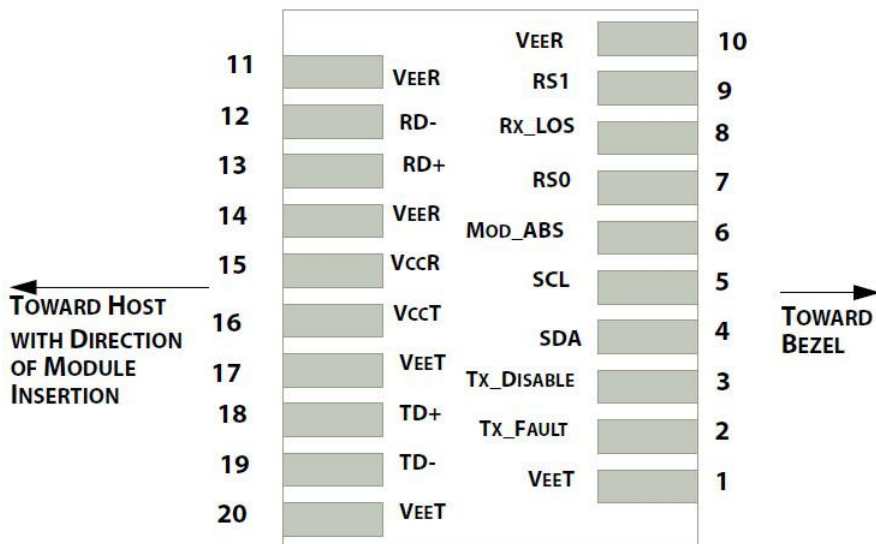

Figure 1 – Diagram of Host Board Connector Block Pin Numbers and Names

Pin	Name	Description	Notes
1	VeeT	Module transmitter ground	1
2	Fault	Module transmitter Fault	2
3	Disable	Transmitter Disable; Turns off transmitter laser output	3
4	SDL	2 wire serial interface data input/output (SDA)	4
5	SCL	2 wire serial interface clock input (SCL)	4
6	MOD-ABS	Module Absent, connect to VeeR or VeeT in the module	2
7	RS0	Rate select0: module inputs and are pulled low to VeeT with > 30 kΩ resistors in the module.	
8	LOS	Receiver Loss of Signal Indication	
9	RS1	Rate select1: module inputs and are pulled low to VeeT with > 30 kΩ resistors in the module.	
10	VeeR	Module receiver ground	1
11	VeeR	Module receiver ground	1
12	RD-	Receiver inverted data out put	
13	RD+	Receiver non-inverted data out put	
14	VeeR	Module receiver ground	1
15	VccR	Module receiver 3.3V supply	
16	VccT	Module transmitter 3.3V supply	
17	VeeT	Module transmitter ground	1
18	TD+	Transmitter non-inverted data out put	
19	TD-	Transmitter inverted data out put	
20	VeeT	Module transmitter ground	1

Notes:

- 1.The module ground pins shall be isolated from the module case.
- 2.This pin is an open collector/drain output pin and shall be pulled up with 4.7K-10Kohms to Host_Vcc on the host board.
- 3.This pin shall be pulled up with 4.7K-10Kohms to VccT in the module.
- 4.This pin is an open collector/drain output pin and shall be pulled up with 4.7K-10Kohms to Host_Vcc on the host board.

VII. Recommended Circuit

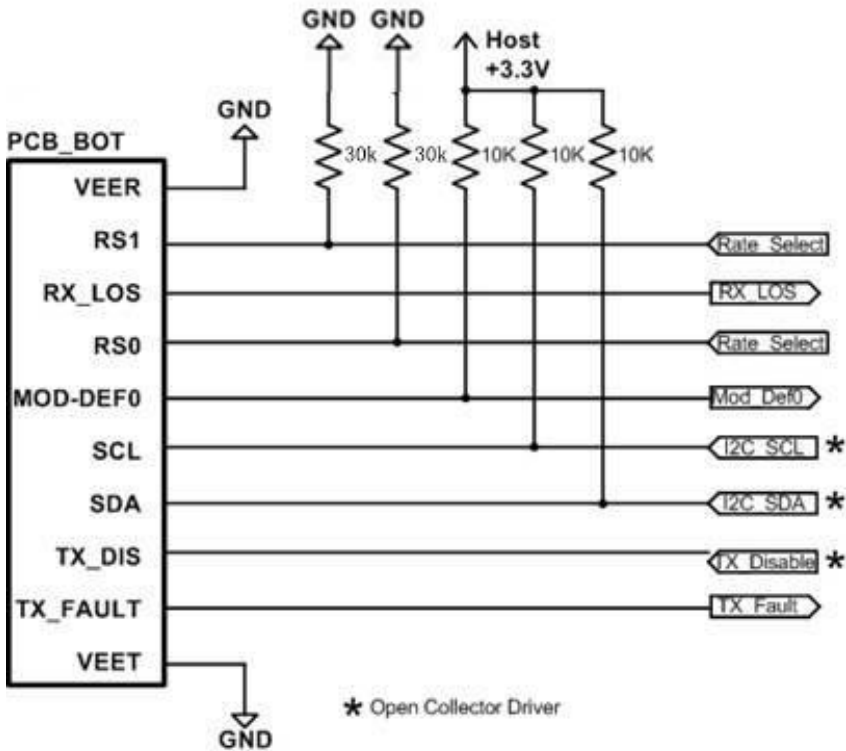
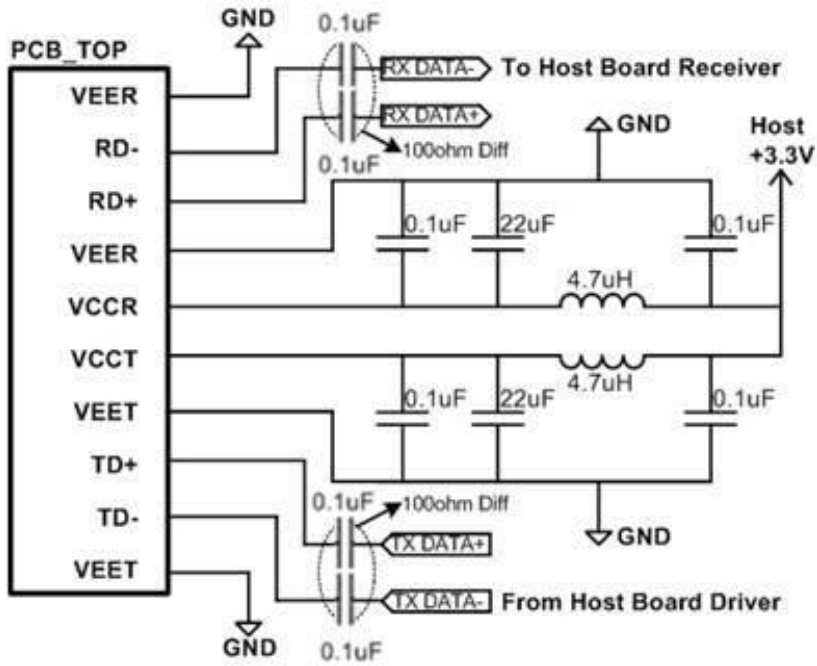

Recommended High-speed Interface Circuit

VIII. Transceiver Block Diagram

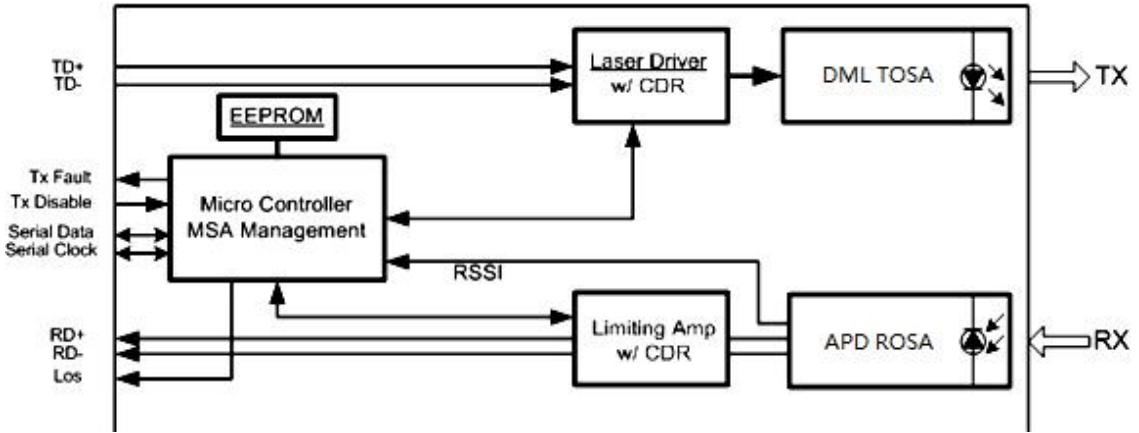

IX. Mechanical Dimensions

