

10GBASE-ER SFP+ 1310nm 40km DOM Transceiver

JD094A-40-LL



Application

- 10GBASE-LR/LW 10G
- Ethernet
- 10GFC
- 8GFC

Features

- Link lengths at 10G 40Km with DFB 1310nm
- 0°C to 70°C operating temperature range
- Digital Monitoring
- LC duplex connector
- Single +3.3V \pm 5% power supply
- SFF-8472 compliant
- Low power consumption < 1.3W

Description

The 10Gigabit 1310nm DFB Transceiver is designed to transmit and receive serial optical data links up from 6.1 Gb/s to 10.52 Gb/s data rate over 30km singlemode fiber. The Transceiver is compliant with SFF-8432, 10GFC, FC-PI-4, IEEE802.3ae and applicable portions of SFF-8431. Digital diagnostics functions are available via a 2-wire serial interface, as specified in SFF-8472.

Product Specifications

I. Absolute Maximum Ratings

Parameter	Symbol	Unit	Min	Max
Storage Temperature Range	T _s	°C	0	70
Relative Humidity	RH	%	0	95
Supply Voltage	VCC	V	-0.3	4.0

II. Recommended Operating Conditions

Parameter	Symbol	Unit	Min	Typ	Max
Operating Case Temperature Range	T _c	°C	0		70
Power Supply Voltage	V _{cc}	V	3.14	3.3	3.46
Bit Rate	BR	Gb/s	6.1		10.52
Bit Error Ratio	BER				10 ⁻¹²
Max Supported Link Length	L	km			30

III. Electric Ports Definition

Parameter	Symbol	Unit	Min	Typ	Max	Note
Supply Voltage	V_{CC}	V	3.14	3.3	3.46	
Supply Current	I_{CC}	mA			390	
Transmitter						
Input Differential Impedance	RIN	Ω	80	100	120	1
Differential Data Input Swing	VIN	mVp-p	180		700	
Transmit Disable Voltage	VDIS	V	2		VCCHOST	
Transmit Enable Voltage	VEN	V	VEE		VEE+0.8	
Transmit Fault Assert Voltage	VFA	V	2.2		VCCHOST	
Transmit Fault De-Assert Voltage	VFDA	V	VEE		VEE+0.4	
Receiver						
Differential Data Output Swing	VOD	mVp-p	450	600	850	
Output Rise Time	tRISE	ps	25			
Output Fall Time	tFALL	ps	25			
LOS Fault	VLOSFT	V	2		VCCHOST	
LOS Normal	VLOSNR	V	VEE		VEE+0.8	

Note:

1. Differential between TD+ / TD-

IV. Principle diagram

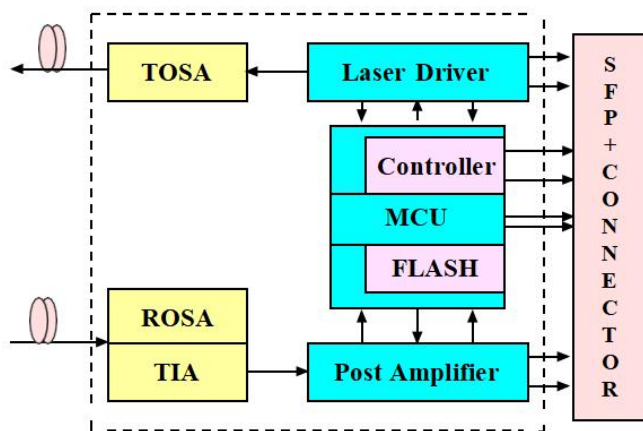

V. Optical Characteristics

Parameter	Symbol	Unit	Min	Typ	Max	Note
-----------	--------	------	-----	-----	-----	------

Transmitter

Nominal Wavelength	λ	nm	1260	1310	1355	
Side Mode Suppression Ratio	SMSR	dB	30			
Spectral width	$\Delta\lambda$	nm			1	
Optical Output Power	P_{av}	dBm			1	20km
					3	30km
Optical Modulation Amplitude¹	P_{OMA}	dBm	-5			20km
			-1			30km
Extinction Ratio	ER	dB	3.5			
Average launch power of OFF transmitter	P_{OFF}	dBm			-35	
Relative Intensity Noise	R_{IN}	dB/Hz			-128	

Optical Return Loss Tolerance	ORLT	dB	-15			
Receiver						
Center Wavelength	λ	nm	1260		1610	
Average Receiver Power	P_{AVG}	dBm			+1	
Receiver Sensitivity² (OMA)	R_{SENSE1}	dBm			-15	PRBS7
Receiver Reflectance	R_{REFL}	dB			-15	
Assert LOS	LOS_A	dBm	-30			
De-Assert LOS	LOS_D	dBm			-17	
LOS Hysteresis		dB	0.5			

Note:

1. OMA = OMAmin – TDP, sum of all penalties incorporated, incl. aging and interoperability margin
2. achieved with worst case jitter stress at δt , and maximum reflection at γt , Jitter total @ δt , BER<10⁻¹² = 0.28UI (informative)

VI. Pin function definitions

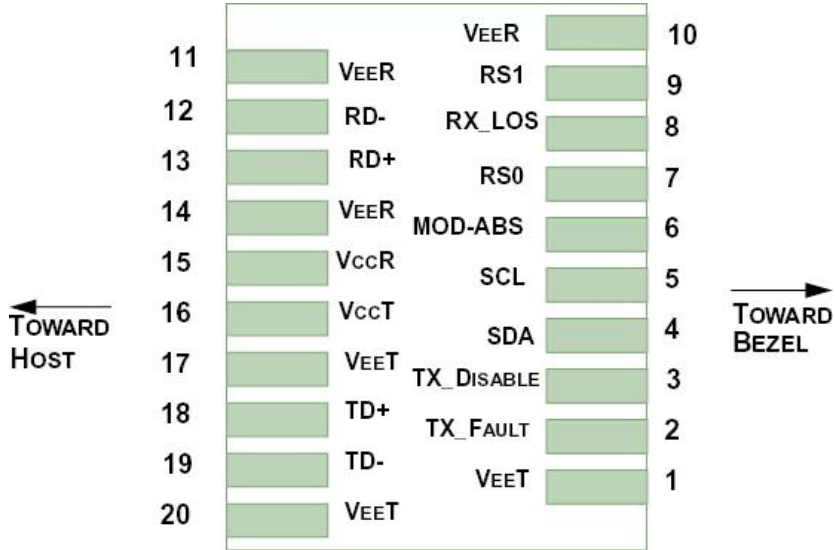

VII. Typical Application Circuit

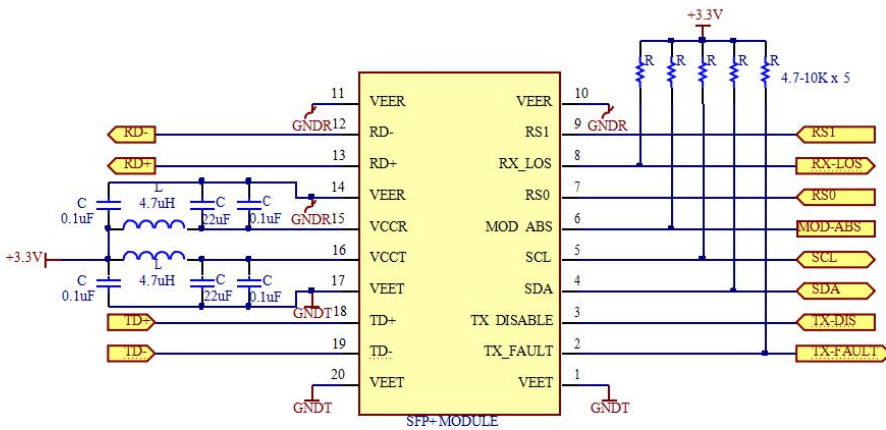

VIII. Package Outline

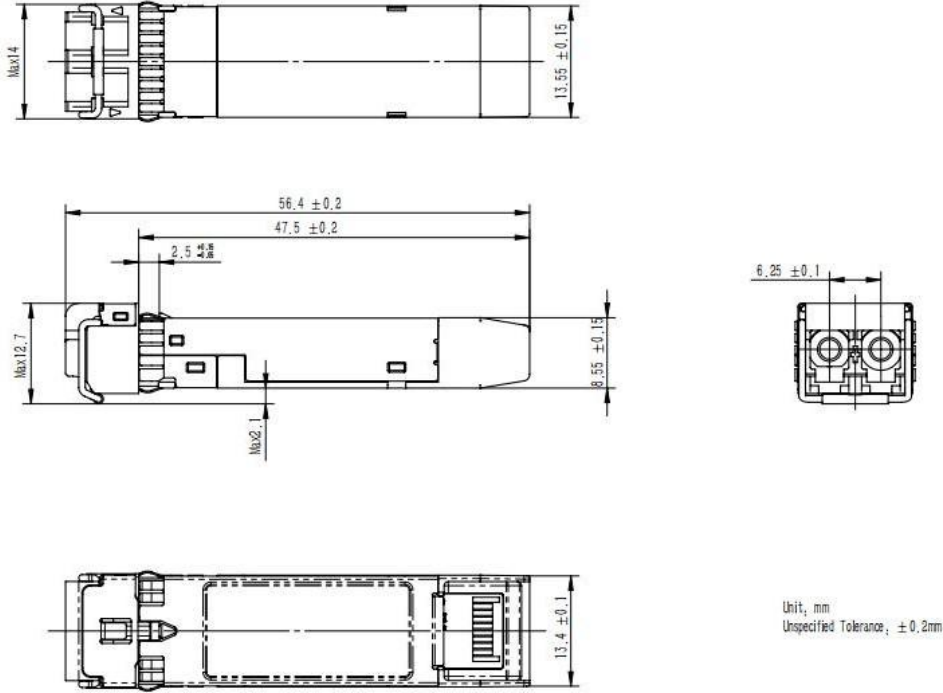

IX. Regulatory Compliance

Feature	Test Method	Performance
Electrostatic Discharge (ESD) to the Electrical Pins	MIL-STD-883C Method 3015.7	Class 1 (> 1500 Volts)
Electrostatic Discharge (ESD) Immunity	Variation of IEC 61000-4-2	LV 4 (Air discharge :15KV; Contact discharge: 8 KV) Performance criterion:B
Electromagnetic Interference (EMI)	CISPR22 ITE Class B EN55022 Class B FCC Class B	Compliant with standards
Immunity	6100IEC61000-4-3 Class 2 EN55024	Typically show no measurable effect from a 3V/m field swept from 80 to 1000MHz applied to the transceiver without a chassis enclosure.