

OC-48/STM-16 SR-1 SFP 1310nm 2km DOM LC SMF Transceiver

JD084A-LL



Applications

- SONET OC48 / SDH STM-16
- SONET OC-12 / SDH STM -4
- SONET OC-3 / SDH STM -1
- 1X/2X Fiber Channel
- Other Optical Link

Features

- Up to 2.5Gb/s Data Links
- Hot-Pluggable
- 1310nm FP Laser Transmitter
- Duplex LC Connector
- RoHS Compliant and Lead Free
- Up to 2km on 9/125 μ m SMF
- Single +3.3V Power Supply
- Monitoring Interface Compliant with SFF-8472
- Commercial Operating Temperature Range: 0°C to 70°C

Description

SFP 2.5Gb/s LR 2km transceiver is a high performance, cost effective module which has a duplex LC optics interface. Standard DC coupled CML for high speed signal and LVTTTL control and monitor signals. The receiver section uses a PIN receiver and the transmitter uses 1310 nm FP laser, up to 8dB link budget ensures this module STM-16/OC-48 2km application.

Product Specifications

I. Absolute Maximum Ratings

Parameter	Symbol	Min.	Typical	Max.	Unit
Storage Temperature	T_S	-40		+85	°C
Supply Voltage	V_{CC}	-0.5		4	V
Relative Humidity	RH	0		85	%

II. Recommended Operating Environment

Parameter	Symbol	Min.	Typical	Max.	Unit
Case Operating Temperature	Commercial T_C	0		+70	°C
Supply Voltage	V_{CC}	3.135		3.465	V
Supply Current	I_{CC}			300	mA
Inrush Current	I_{surge}			$I_{CC}+30$	mA
Maximum Power	P_{max}			0.7	W

III. Electrical Characteristics (TOP = T_c ° C, V_{CC} = 3.0 to 3.60 Volts)

Parameter	Symbol	Min.	Typical	Max.	Unit	Note
Transmitter Section						
Input Differential Impedance	R _{in}	90	100	110		
Single Ended Data Input Swing	V _{in} PP	200		1200	mVp-p	
Transmit Disable Voltage	V _D	V _{CC} - 1.3		V _{CC}	V	2
Transmit Enable Voltage	V _{EN}	V _{ee}		V _{ee} +0.8	V	
Transmit Disable Assert Time	T _{dessert}			10	us	
Receiver Section						
Single Ended Data Output Swing	V _{out} pp	300		1000	mv	3
Data Output Rise Time	t _r			260	ps	4
Data Output Fall Time	t _f			260	ps	4
LOS Fault	V _{losfault}	V _{CC} - 0.5		V _{CC} _host	V	5
LOS Normal	V _{los norm}	V _{ee}		V _{ee} +0.5	V	5
Power Supply Rejection	PSR	100			mVpp	6
Total Generated Receiver Jitter (peak to peak)	J _{RXp-p}			0.07	UI	
Total Generated Receiver Jitter (rms)	J _{RXrms}			0.007	UI	

Note:

1. AC coupled.
2. Or open circuit.
3. Into 100 ohm differential termination.

4. 20 – 80 %.

5. LOS is LVTTTL. Logic 0 indicates normal operation; logic 1 indicates no signal detected.

6. All transceiver specifications are compliant with a power supply sinusoidal modulation of 20 Hz to 1.5MHz up to specified value applied through the power supply filtering network shown on page 23 of the Small Form-factor Pluggable (SFP) Transceiver Multi-Source Agreement (MSA), September 14, 2000.

IV. Optical Parameters (TOP =TC, V_{CC} = 3.0 to 3.60 Volts)

Parameter	Symbol	Min.	Typical	Max.	Unit	Note
-----------	--------	------	---------	------	------	------

Transmitter Section

Center Wavelength	λ_c	1270	1310	1360	nm	
Spectral Width (RMS)	σ_{RMS}			4	nm	
Optical Output Power	P_{out}	-10		-3	dBm	1
Extinction Ratio	ER	8.2			dB	
Optical Rise/Fall Time	t_r/t_f			260	ps	2
Relative Intensity Noise	RIN			-120	dB/Hz	
Total Generated Transmitter Jitter (peak to peak)	J_{TXp-p}			0.07	UI	
Total Generated Transmitter Jitter(rms)	J_{TXrms}			0.007	UI	
Output Eye Mask	Compliant with eye mask Telcordia GR-253-GORE					

Receiver Section

Optical Input Wavelength	λ_c	1260		1360	nm	
RX Sensitivity @ OC-48/STM-16	Sen1			-18	dBm	3

Parameter	Symbol	Min.	Typical	Max.	Unit	Note
RX Sensitivity @ 2xFibre Channel	Sen2			-19	dBm	4
RX Sensitivity @ Gigabit Ethernet	Sen3			-19	dBm	4
RX Sensitivity @ OC-12/STM-4	Sen4			-19	dBm	5
RX Sensitivity @ OC-4/STM-1	Sen5			-19	dBm	5
RX_LOS A_{assert}	LOS _A	-35			dBm	
RX_LOS D_{e-assert}	LOS _D			-19	dBm	
RX_LOS Hysteresis	LOS _H	0.5			dB	

V. General Specifications

Parameter	Symbol	Min.	Typical	Max.	Unit	Note
Data Rate	BR	155		2667	Mb/s	
Bit Error Rate	BER			10 ⁻¹²		
Max. Supported Link Length on 9/125µm SMF @ OC-48/STM-16	L _{MAX1}		2		km	
Max. Supported Link Length on 9/125µm SMF @ 2xFibre Channel	L _{MAX2}		5		km	
Max. Supported Link Length on 9/125µm SMF @ Gigabit Ethernet	L _{MAX3}		10		km	
Max. Supported Link Length on 9/125µm SMF @ OC-12/STM-4	L _{MAX4}		10		km	
Max. Supported Link Length on 9/125µm SMF @ OC-4/STM-1	L _{MAX5}		10		km	

Note:

- Compliant with FDA/CDRH and EN (IEC) 60825 regulations (Class 1 Laser Safety).

2. 20-80%.
3. Measured with PRBS 231-1 at 10-12 BER.
4. Measured with PRBS 27-1 at 10-12 BER.
5. Measured with PRBS 223-1 at 10-12 BER.

VI. Digital Diagnostic Monitor Characteristics (A2h)

Data Address	Parameter	Accuracy	Unit
96-97	Transceiver Internal Temperature	± 3.0	° C
98-99	V _{CC3} Internal Supply Voltage	± 5.0	%
100-101	Laser Bias Current	± 10	%
102-103	Tx Output Power	± 3.0	dBm
104-105	Rx Input Power	± 3.0	dBm

VII. Regulatory Compliance

The OP3602D complies with international Electromagnetic Compatibility (EMC) and international safety requirements and standards (see details in Table following).

Electrostatic Discharge (ESD) to the Electrical Pins	MIL-STD-883E Method 3015.7	Class 1(>1000 V)
Electrostatic Discharge (ESD) to the Duplex LC Receptacle	IEC 61000-4-2GR-1089-CORE	Compatible with standards
Electromagnetic Interference (EMI)	FCC Part 15 Class BEN55022 Class B (CISPR 22B) V _{CC} I Class B	Compatible with standards

VIII. Pin Assignment

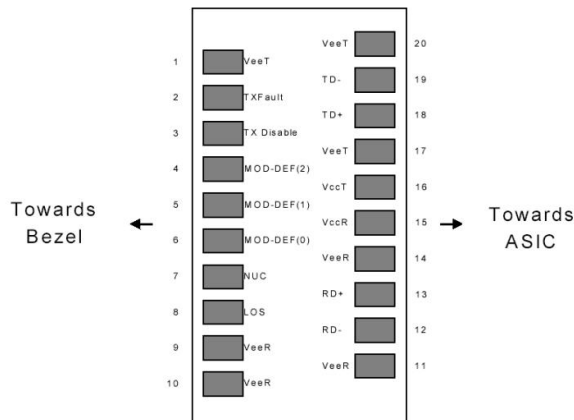

Figure 1. Diagram of Host Board Connector Block Pin Numbers and Names

IX. Pin Description

Pin No	Name	Function	Plug Seq	Notes
1	V_{eeT}	Transmitter Ground	1	1
2	TX Fault	Transmitter Fault Indication	3	
3	TX Disable	Transmitter Disable	3	2
4	MOD-DEF2	Module Definition	2	3
5	MOD-DEF1	Module Definition 1	3	3
6	MOD-DEF0	Module Definition 0	3	3
7	Rate Select	Not Connected	3	4
8	LOS	Loss of Signal	3	5
9	V_{eeR}	Receiver Ground	1	1
10	V_{eeR}	Receiver Ground	1	1
11	V_{eeR}	Receiver Ground		1
12	RD-	Inv.Received Data Out	3	6
13	RD+	Received Data Out	3	6
14	V_{eeR}	Receiver Ground	3	1
15	V_{ccR}	Receiver Power	2	1
16	V_{ccT}	Transmitter Power	2	

Pin No	Name	Function	Plug Seq	Notes
17	V _{ee} T	Transmitter Ground	1	
18	TD+	Transmit Data In	3	6
19	TD-	Inv.Transmit In	3	6
20	V _{ee} T	Transmitter Ground	1	

Notes:

1. Circuit ground is internally isolated from chassis ground.
2. Laser output disabled on TDIS >2.0V or open, enabled on TDIS <0.8V.
3. Should be pulled up with 4.7k - 10 kohms on host board to a voltage between 2.0V and 3.6V.MOD_DEF(0) pulls line low to indicate module is plugged in.
4. Rate select is not used.
5. LOS is open collector output. Should be pulled up with 4.7k – 10 kohms on host board to a voltage between 2.0V and 3.6V. Logic 0 indicates normal operation; logic 1 indicates loss of signal.
6. AC Coupled.

X. Recommended Circuit

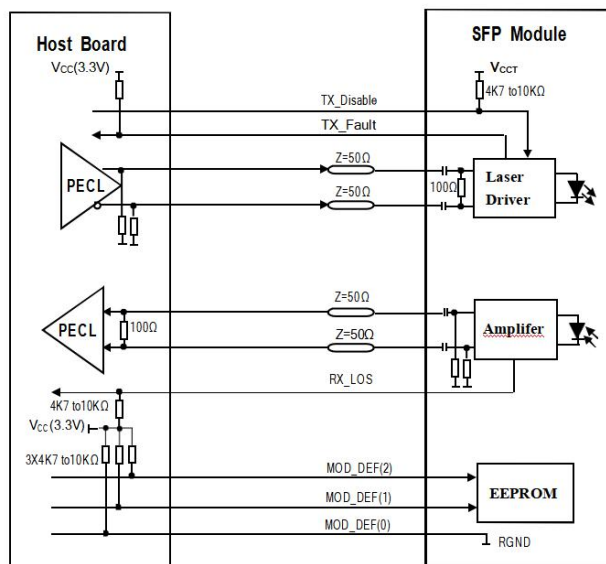

Figure 2. SFP Host Recommended Circuit

XI. Serial ID Memory Contentsn

Data Address	Length(Byte)	Name of Length	Description and Contents
Base ID Fields			
0	1	Identifier	Type ofSerial transceiver (03h=SFP)
1	1	Reserved	Extended identifier of type serial transceiver(04h)
2	1	Connector	Code of optical connector type (07=LC)
3-10	8	Transceiver	
11	1	Encoding	NRZ(03h)
12	1	BR, Nominal	Nominal baud rate, unit of 100Mbps
13	1	Reserved	(0000h)
14	1	Length (9um,km)	Link length supported for 9/125um fiber, units of km
15	1	Length (9um)	Link length supported for 9/125um fiber, units of 100m
16	1	Length (50um)	Link length supported for 50/125um fiber, units of 10m
17	1	Length (62.5um)	Link length supported for 62.5/125um fiber, units of 10m
18	1	Length (Copper)	Link length supported for copper, units of meters
19	1	Reserved	
20-35	16	Vendor Name	SFP vendor name:
36	1	Reserved	
37-39	3	Vendor OUI	SFP transceiver vendor OUI ID

Data Address	Length(Byte)	Name of Length	Description and Contents
40-55	16	Vendor PN	PartNumber: "LonglineXXXXXX" (ASCII)
56-59	4	Vendor rev	Revision level for part number
60-61	2	Wavelength	Laser wavelength
62	1	Reserved	
63	1	CCID	Least significant byte of sum of data in address 0-62
Extended ID Fields			
64-65	2	Option	Indicates which optical SFP signals are implemented (001Ah=LOS, TX_FAULT, TX_DISABLE all supported)
66	1	BR, max	Upper bit rate margin, units of %
67	1	BR, min	Lower bit rate margin, units of %
68-83	16	Vendor SN	Serial number (ASCII)
84-91	8	Date code	Manufacturing date code
92	1	Diagnostic Type	Diagnostics
93	1	Enhanced Options	Diagnostics
94	1	SFF-8472	Diagnostics
95	1	CCEX	Check code for the extended ID Fields (addresses 64 to 94)
Vendor Specific ID Fields			
96-127	32	Readable	Vendor specific data, readonly

Data Address	Length (Byte)	Name of Length	Description and Contents
128-255	128	Reserved	Reserved for SFF-8079

XII. Mechanical Dimensions

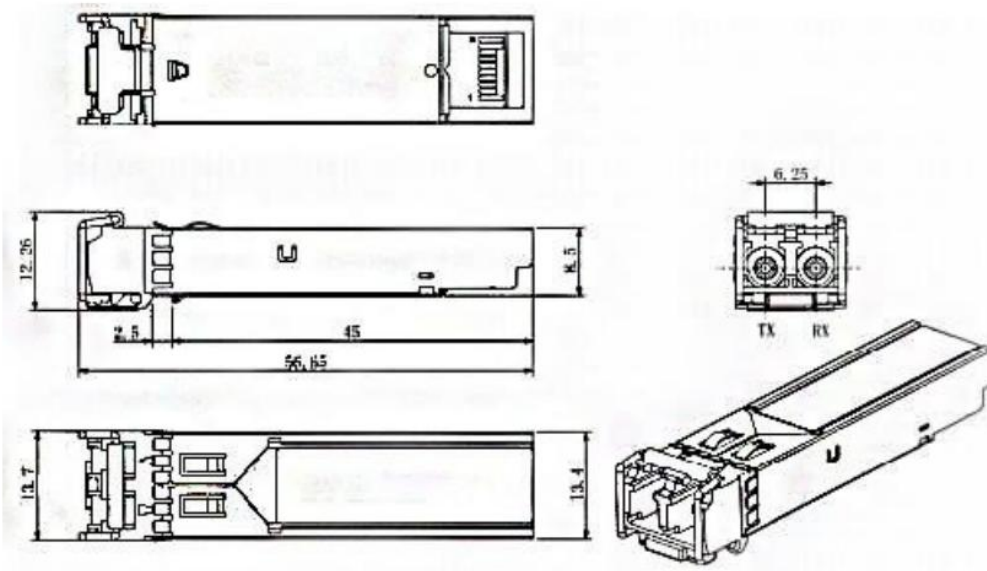

Figure 3. Mechanical Drawing