

10GBASE-LRM XFP 1310nm 220m DOM Duplex LC Transceiver

J9144A-LL



Application

- 10GBASE-LRM Ethernet
- Legacy FDDI Multimode Links
- 10G Fibre Channel
- SONET OC-192/SDH STM-64
- Other Optical Links

Standards

- XFP MSA Compliant

Features

- Hot Pluggable 30 Pin Connector
- Support Multi Protocol from 9.95Gb/s to 11.3Gb/s
- Duplex LC Connector
- Transmission Distance of 220m over MMF
- Low Power Consumption < 1.5W
- Single 3.3V Supply Voltage
- XFP Electrical Interface with AC Coupling
- 1310nm FP Laser Transmitter
- Operating Case Temperature Range: 0 ~ 70°C
- 2-Wire Interface with Integrated Digital Diagnostic Monitoring

Description

The 10G XFP Optical Transceiver Module supports up to 220m link lengths over OM3 MMF via an LC duplex connector. The transceiver is compliant with CPRI, eCPRI. Digital diagnostics functions are available via a 2-wire serial interface, as specified in the XFP MSA.

With these features, this 10G SFP+ transceiver is ideal for data centers, 10G fibre channel, legacy FDDI multimode links, etc.

Product Specifications

I. Absolute Maximum Ratings

Parameter	Symbol	Min.	Max.	Unit
Storage Temperature	T_{ST}	-40	85	°C
Case Operating Temperature	T_C	0	70	°C
Supply Voltage	V_{CC3}	-0.5	4.0	V

II. Recommended Operating Conditions

Parameter	Symbol	Min.	Typical	Max.	Unit	Notes
Operating Case Temperature	T_{OPR}	0		70	°C	
Supply Voltage	V_{CC3}	3.135		3.465	V	
Supply Current	I_{CC3}			380	mA	
Module Total Power	P			1.5	W	

III. Optical Characteristics

Parameter	Symbol	Min.	Typ.	Max.	Unit	Notes
Transmitter						
Operating Bit Rate	BR	9.95		11.3	Gb/s	
Bit Error Rate	BER			10 ⁻¹²		
Launch Power	P _{OUT}	-7.3		-1	dBm	1
Optical Wavelength	λ	1260	1310	1355	nm	
Optical Extinction Ratio	ER	3.5			dB	
RMS Spectral Width	λ _{RMS}			4	nm	
Rise/Fall Time (20%~80%)	T _r /T _f			35	ps	
Average Launch Power of OFF Transmitter	P _{OFF}			-30	dBm	
Tx Jitter	T _{xj}	Compliant with each Standard Requirements				
Optical Eye Mask		IEEE802.3aq				2
Receiver						
Operating Bit Rate	BR	9.95		11.3	Gb/s	
Receiver Sensitivity	Sen			-11.1	dBm	2
Maximum Input Power	P _{MAX}	0			dBm	2
Optical Center Wavelength	λ _C	1260		1355	nm	
Receiver Reflectance	R _{rx}			-12	dB	
LOS De-assert	LOS _D			-12	dBm	

Parameter	Symbol	Min.	Typ.	Max.	Unit	Notes
LOS Assert	LOS _A	-30			dBm	
LOS Hysteresis	LOS _H	0.5		5	dB	

Notes:

1. The optical power is launched into MMF.
2. Measured with a PRBS 231-1 test pattern@10.3125Gbps BER<10⁻¹².

IV. Electrical Characteristics

Parameter	Symbol	Min.	Typ.	Max.	Unit	Notes
Transmitter						
Input Differential Impedance	R _{IN}		100		Ω	1
Differential Data Input Swing	V _{IN,PP}	150		820	mV	
Transmit Disable Voltage	V _D	2.0		V _{CC}	V	
Transmit Enable Voltage	V _{EN}	GND		GND+0.8	V	
Transmit Disable Assert Time	T _{off}			100	ms	
Tx Enable Assert Time	T _{on}			100	ms	
Receiver						
Differential Data Output Swing	V _{OUT,PP}	300	500	850	mV	
Data Output Rise Time	t _r			35	ps	2
Data Output Fall Time	t _f			35	ps	2
LOS Fault	V _{LOS fault}	V _{CC} -0.5		V _{CCHOST}	V	3

Parameter	Symbol	Min.	Typ.	Max.	Unit	Note
LOS Normal	$V_{LOS\ norm}$	GND		GND+0.5	V	3
Power Supply Rejection	PSR		See Note 4 Below			4

Notes:

1. After internal AC coupling.
2. 20 – 80%.
3. Loss of Signal is open collector to be pulled up with a 4.7k–10kohm resistor to 3.15–3.6V. Logic 0 indicates normal operation; Logic 1 indicates no signal detected.
4. Per Section 2.7.1 in the XFP MSA specification.

V. Pin Definitions

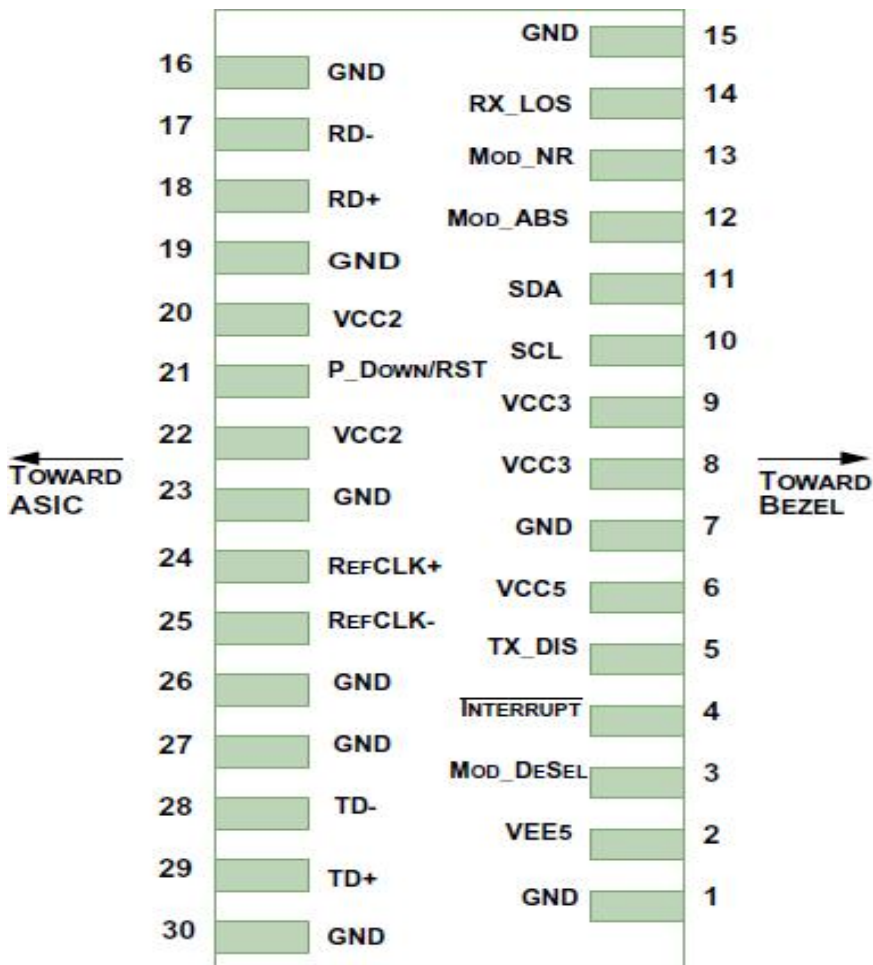

Diagram of Host Board Connector Block Pin Numbers and Name (Top View)

Pin	Logic	Symbol	Name/Description	Ref.
1		GND	Module Ground	1
2		V _{EE} 5	Optional-5.2V Power Supply- Not Required	
3	LVTTTL-I	Mod-Desel	Module De-select; When Held Low Allows the Module to, Respond to 2-wire Serial Interface Commands	
4	LVTTTL-O	Interrupt	Interrupt (Bar); Indicates Presence of an Important Condition Which can Be read over the Serial 2-Wire Interface	2
5	LVTTTL-I	Tx_DIS	Transmitter Disable; Transmitter Laser Source Turned off	
6		V _{CC} 5	5V Power Supply	
7		GND	Module Ground	1
8		V _{CC} 3	3.3V Power Supply	
9		V _{CC} 3	3.3V Power Supply	
10	LVTTTL-I	SCL	Serial 2-Wire Interface Clock	2
11	LVTTTL-I/O	SDA	Serial 2-Wire Interface Data Line	2
12	LVTTTL-O	Mod_Abs	Module Absent; Indicates Module is Not Present. Grounded in the Module.	2
13	LVTTTL-O	Mod_NR	Module Not Ready	2
14	LVTTTL-O	Rx_LOS	Receiver Loss of Signal Indicator	2
15		GND	Module Ground	1
16		GND	Module Ground	1
17	CML-O	RD-	Receiver Inverted Data Output	

Pin	Logic	Symbol	Name/Description	Ref.
18	CML-O	RD+	Receiver Non-Inverted Data Output	
19		GND	Module Ground	1
20		V _{CC2}	1.8V Power Supply–Not Required	
21	LVTTL-I	P_Down/RST	Power Down; When High, Places the Module in the Low Power Stand-by Mode and on the Falling Edge of P_Down Initiates a Module Reset	
			Reset; The Falling Edge Initiates a Complete Reset of the Module Including the 2-Wire Serial Interface, Equivalent to a Power Cycle.	
22		V _{CC2}	1.8V Power Supply–Not Required	
23		GND	Module Ground	1
24	PECL-I	RefCLK+	Reference Clock Non-Inverted Input, AC Coupled on the Host Board–Not Required	3
25	PECL-I	RefCLK-	Reference Clock Inverted Input, AC Coupled on the Host Board–Not Required	3
26		GND	Module Ground	1
27		GND	Module Ground	1
28	CML-I	TD-	Transmitter Inverted Data Input	
29	CML-I	TD+	Transmitter Non-Inverted Data Input	
30		GND	Module Ground	1

Notes:

1. Module circuit ground is isolated from module chassis ground within the module.
2. Open collector; Should be pulled up with 4.7k–10k ohms on host board to a voltage between 3.15V and 3.6V.
3. A reference clock input is not required.

VI. Recommended Circuit:

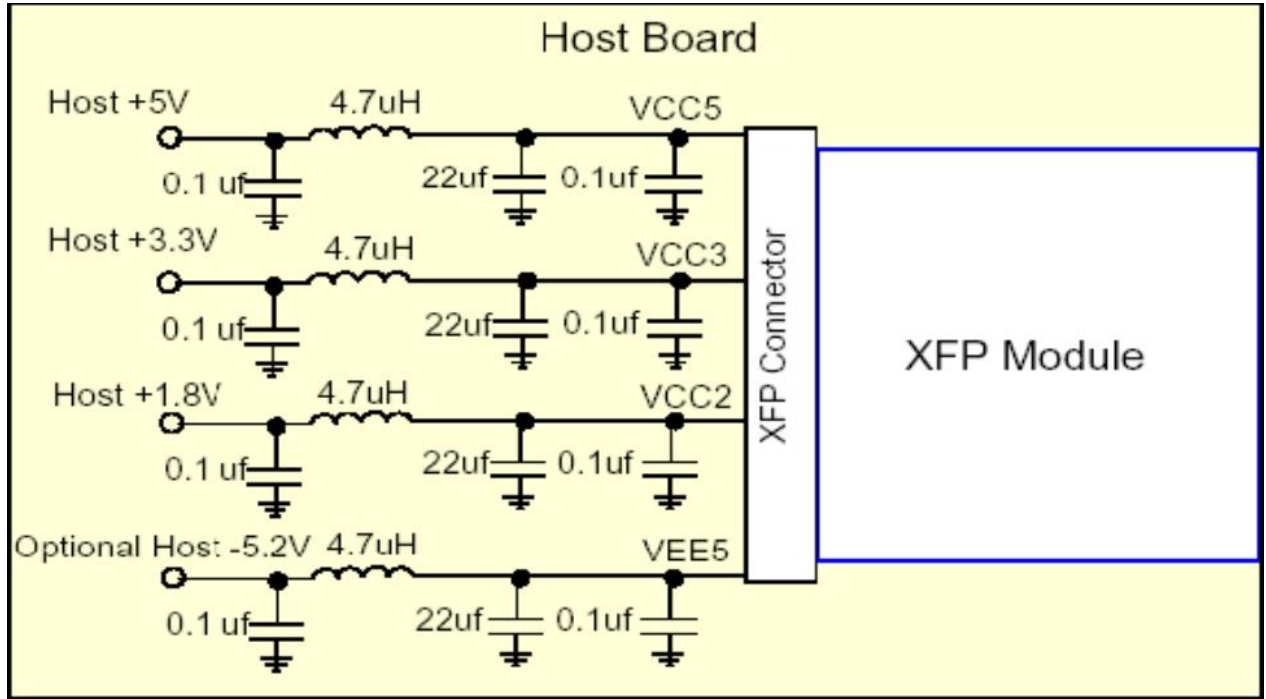

VII. Recommended Host Board Power Supply Circuit

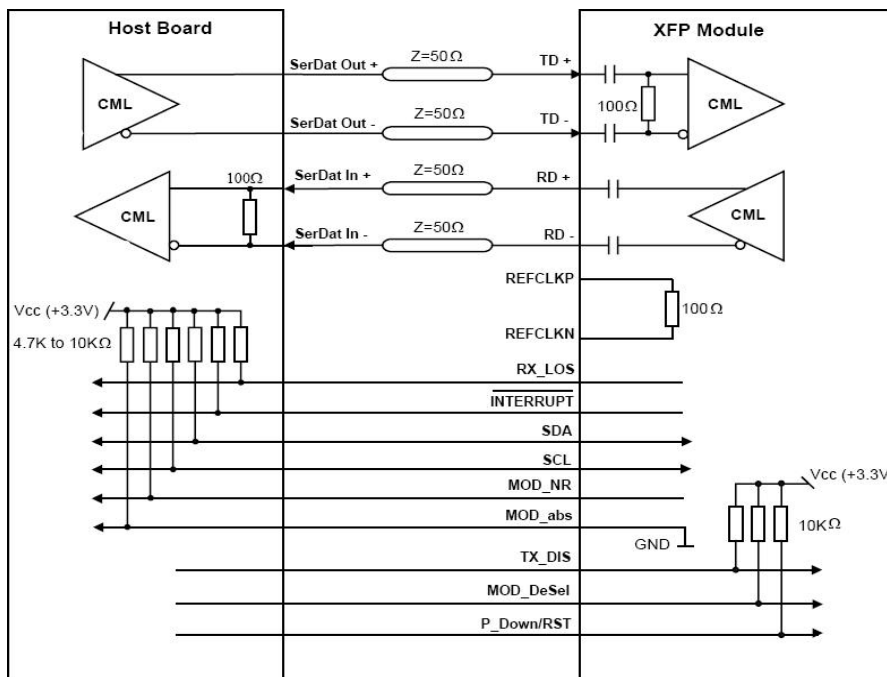

VIII. Digital Diagnostic Functions:

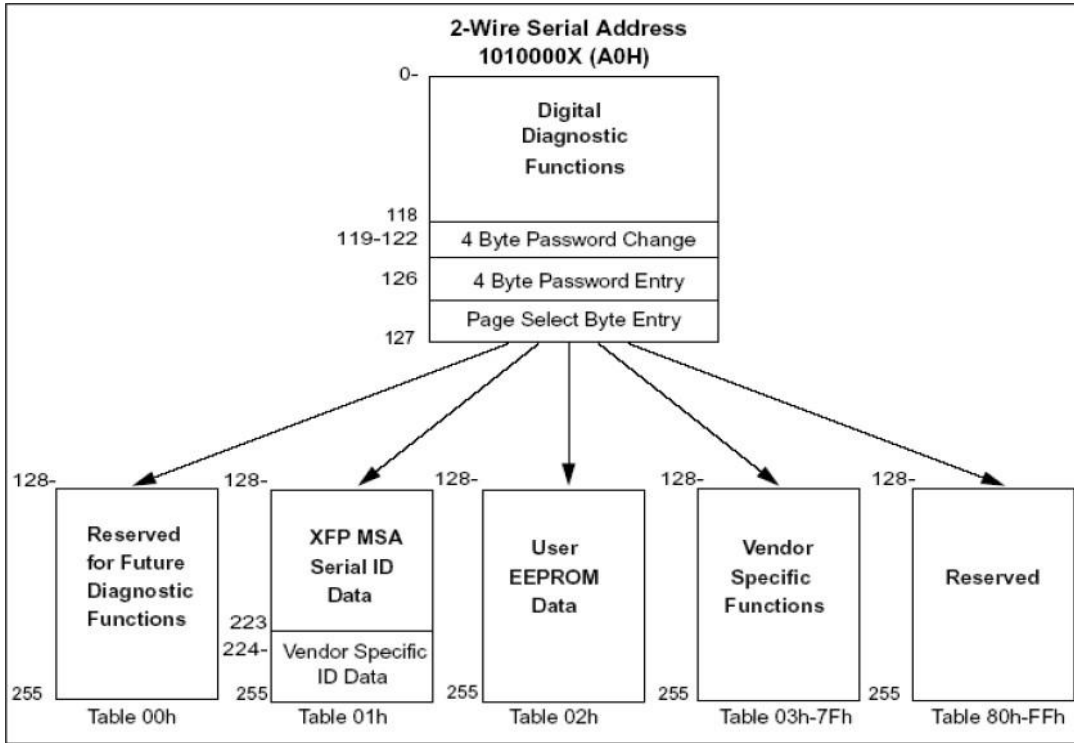

As defined by the XFP MSA 1, Longline’s XFP transceivers provide digital diagnostic functions via a 2-wire serial interface, which allows real-time access to the following operating parameters:

1. Transceiver temperature
2. Laser bias current
3. Transmitted optical power
4. Received optical power
5. Transceiver supply voltage

It also provides a sophisticated system of alarm and warning flags, which may be used to alert end-users when particular operating parameters are outside of a factory-set normal range.

The operating and diagnostics information is monitored and reported by a Digital Diagnostics Transceiver Controller (DDTC) inside the transceiver, which is accessed through the 2-wire serial interface. When the serial protocol is activated, the serial clock signal (SCL pin) is generated by the host. The positive edge clocks data into the XFP transceiver into those segments of its memory map that are not write-protected. The negative edge clocks data from the XFP transceiver. The serial data signal (SDA pin) is bi-directional for serial data transfer. The host uses SDA in conjunction with SCL to mark the start and end of serial protocol activation. The memories are organized as a series of 8-bit data words that can be addressed individually or sequentially. The 2-wire serial interface provides sequential or random access to the 8 bit parameters, addressed from 000h to the maximum address of the memory.

For more detailed information including memory map definitions, please see the XFP MSA specification.

IX. Mechanical Specifications

Unit: mm

