

10GBASE-ER/EW and OC-192/STM-64 IR-2 XFP 1550nm 40km DOM Transceiver

J8173A-LL

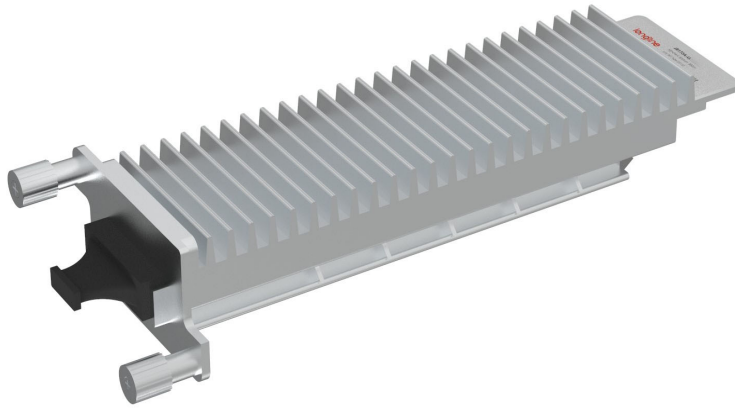

Application

- 10GBASE-ER/EW Ethernet
- SONET OC-192/SDH STM-64
- 40km 10G FC
- Other optical links

Features

- Support multi protocol from 9.95Gb/s to 11.3Gb/s
- Hot pluggable 30 pin connector
- Compliant with XFP MSA
- Transmission distance of 40km over single mode fiber
- Cooled EML laser transmitter.
- DuplexLC connector
- 2-wire interface for management and diagnostic monitor
- XFI electrical interface with AC coupling
- Power supply voltages : +3.3V, +5V
- Temperature range 0° C to 70° C
- Power dissipation: <3W
- RoHS Compliant Part

Description

Longline' J8173A-LL Small Form Factor 10Gb/s (XFP) transceivers are compliant with the current XFP Multi-Source Agreement (MSA) Specification. The high performance cooled 1550nm EML transmitter and high sensitivity PIN receiver provide superior performance for SONET/SDH and Ethernet applications up to 40km optical links.

Product Specifications

I. Absolute Maximum Ratings

Parameter	Symbol	Min	Typ.	Max	Unit	Ref.
Storage Temperature	T_{ST}	-40		+85	°C	
Operating Temperature	T_{OP}	0		+70	°C	
Supply Voltage	V_{CC3}	-0.5		+4.0	V	
Supply Voltage 2	V_{CC5}	-0.5		+6.0	V	

II. Electrical Characteristics

Parameter	Symbol	Min	Typ.	Max	Unit	Ref.
Supply Voltage 1	V_{CC3}	4.75		5.25	V	
Supply Voltage 2	V_{CC5}	3.13		3.45	V	
Supply Current – Vcc5 supply	I_{CC5}			170	mA	
Supply Current – Vcc3 supply	I_{CC3}			500	mA	
Module total power	P			3	W	
Transmitter						
Input differential impedance	R_{in}		100		Ω	1
Differential data input swing	$V_{in,pp}$	120		820	mV	

Transmit Disable Voltage	VD	2.0		Vcc	V	
Transmit Enable Voltage	VEN	GND		GND+ 0.8	V	
Transmit Disable Assert Time	T _{off}			100	ms	
Tx Enable Assert Time	T _{on}			100	ms	

Receiver

Differential data output swing	V _{out,pp}	340		850	mV	
Data output rise time	t _r			35	ps	2
Data output fall time	t _f			35	ps	2
LOS Fault	VLOS fault	Vcc – 0.5		VccHOST	V	3
LOS Normal	VLOS norm	GND		GND+0.4	V	3
Power Supply Rejection	PSR		See Note 4 below			4

Notes:

1. After internal AC coupling.
2. 20 – 80 %
3. Loss Of Signal is open collector to be pulled up with a 4.7k – 10kohm resistor to 3.15 – 3.6V.
Logic 0 indicates normal operation; logic 1 indicates no signal detected.
4. Per Section 2.7.1. in the XFP MSA Specification.

III. Optical Characteristics

Parameter	Symbol	Min	Typ.	Max	Unit	Ref.
Transmitter						
Operating Data Rate	B	9.95		11.3	Gb/s	
Bit Error Rate	BER			10 ⁻¹²		
Output Power	P _o	-1		+4	dBm	1

Optical Wavelength	λ	1530	1550	1565	nm	
Optical Extinction Ratio	ER	8.2			dB	
Spectral Width	$\Delta\lambda$			1	nm	
Sidemode Supression ratio	SSRmin	30			dB	
Rise/Fall Time (20%~80%)	Tr/Tf			35	ps	
Average Launch power of OFF Transmitter	POFF			-30	dBm	
Tx Jitter	Txj	Compliant with each standard requirements				
Optical Eye Mask		IEEE802.3ae				2
Receiver						
Operating Date Rate	B	9.95		11.3	Gb/s	
Receiver Sensitivity@9.95Gb/s	R			-16	dBm	2
Maximum Input Power	PMAX	-3			dBm	2
Optical Center Wavelength	λ_c	1260		1600	nm	
Receiver Reflectance	Rrx			-27	dB	
LOS De-Assert	LOS _D			-17	dBm	
LOS Assert	LOS _A	-30			dBm	
LOS Hysteresis		0.5		5	dB	

Notes:

1. The optical power is launched into SMF.
2. Measured with a PRBS 2³¹-1 test pattern @10.3125Gbps BER<10⁻¹².

IV. Pin Description

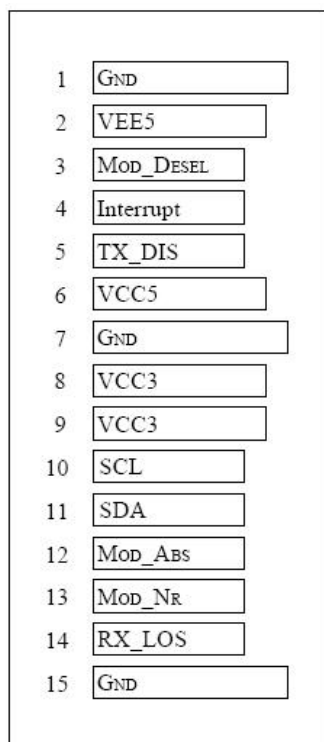

Bottom of Board
(As view through top of board)

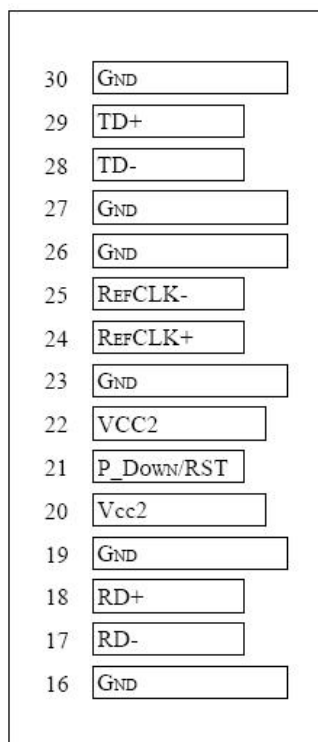

Top of Board

Diagram of Host Board Connector Block Pin Numbers and Name

Pin	Symbol	Name/Description	Notes
1	GND	Module Ground	1
2	VEE5	Optional -5.2 Power Supply – Not required	
3	Mod-Desel	Module De-select; When held low allows the module to respond to 2-wire serial interface commands	
4	Interrupt	Interrupt (bar); Indicates presence of an important condition which can be read over the serial 2-wire interface	2
5	TX_DIS	Transmitter Disable; Transmitter laser source turned off	
6	VCC5	+5 Power Supply	
7	GND	Module Ground	1

8	VCC3	+3.3V Power Supply	
9	VCC3	+3.3V Power Supply	
10	SCL	Serial 2-wire interface clock	2
11	SDA	Serial 2-wire interface data line	2
12	Mod_Abs	Module Absent; Indicates module is not present. Grounded in the module.	2
13	Mod_NR	Module Not Ready;	2
14	RX_LOS	Receiver Loss of Signal indicator	2
15	GND	Module Ground	1
16	GND	Module Ground	1
17	RD-	Receiver inverted data output	
18	RD+	Receiver non-inverted data output	
19	GND	Module Ground	1
20	VCC2	+1.8V Power Supply – Not required	
21	P_Down/RST	Power Down; When high, places the module in the low power stand-by mode and on the falling edge of P_Down initiates a module reset Reset; The falling edge initiates a complete reset of the module including the 2-wire serial interface, equivalent to a power cycle.	
22	VCC2	+1.8V Power Supply – Not required	
23	GND	Module Ground	1
24	RefCLK+	Reference Clock non-inverted input, AC coupled on the host board – Not required	3
25	RefCLK-	Reference Clock inverted input, AC coupled on the host board – Not required	3
26	GND	Module Ground	1
27	GND	Module Ground	1
28	TD-	Transmitter inverted data input	
29	TD+	Transmitter non-inverted data input	
30	GND	Module Ground	1

Note:

1. Module circuit ground is isolated from module chassis ground within the module.
2. Open collector; should be pulled up with 4.7k – 10k ohms on host board to a voltage between 3.15V and 3.6V.
3. A Reference Clock input is not required .

V. Digital Diagnostic Functions

As defined by the XFP MSA 1 , Longline’s XFP transceivers provide digital diagnostic functions via a 2-wire serial interface, which allows real- time access to the following operating parameters:

- √ Transceiver temperature
- √ Laser bias current
- √ Transmitted optical power
- √ Received optical power
- √ Transceiver supply voltage

It also provides a sophisticated system of alarm and warning flags, which may be used to alert end-users when particular operating parameters are outside of a factory-set normal range.

The operating and diagnostics information is monitored and reported by a Digital Diagnostics Transceiver Controller (DDTC) inside the transceiver, which is accessed through the 2-wire serial interface. When the serial protocol is activated, the serial clock signal (SCL pin) is generated by the host. The positive edge clocks data into the XFP transceiver into those segments of its memory map that are not write-protected. The negative edge clocks data from the XFP transceiver. The serial data signal (SDA pin) is bi-directional for serial data transfer. The host uses SDA in conjunction with SCL to mark the start and end of serial protocol activation. The memories are organized as a series of 8-bit data words that can be addressed individually or sequentially. The 2-wire serial interface provides sequential or random access to the 8 bit parameters, addressed from 000h to the maximum address of the memory.

For more detailed information including memory map definitions, please see the XFP MSA Specification.

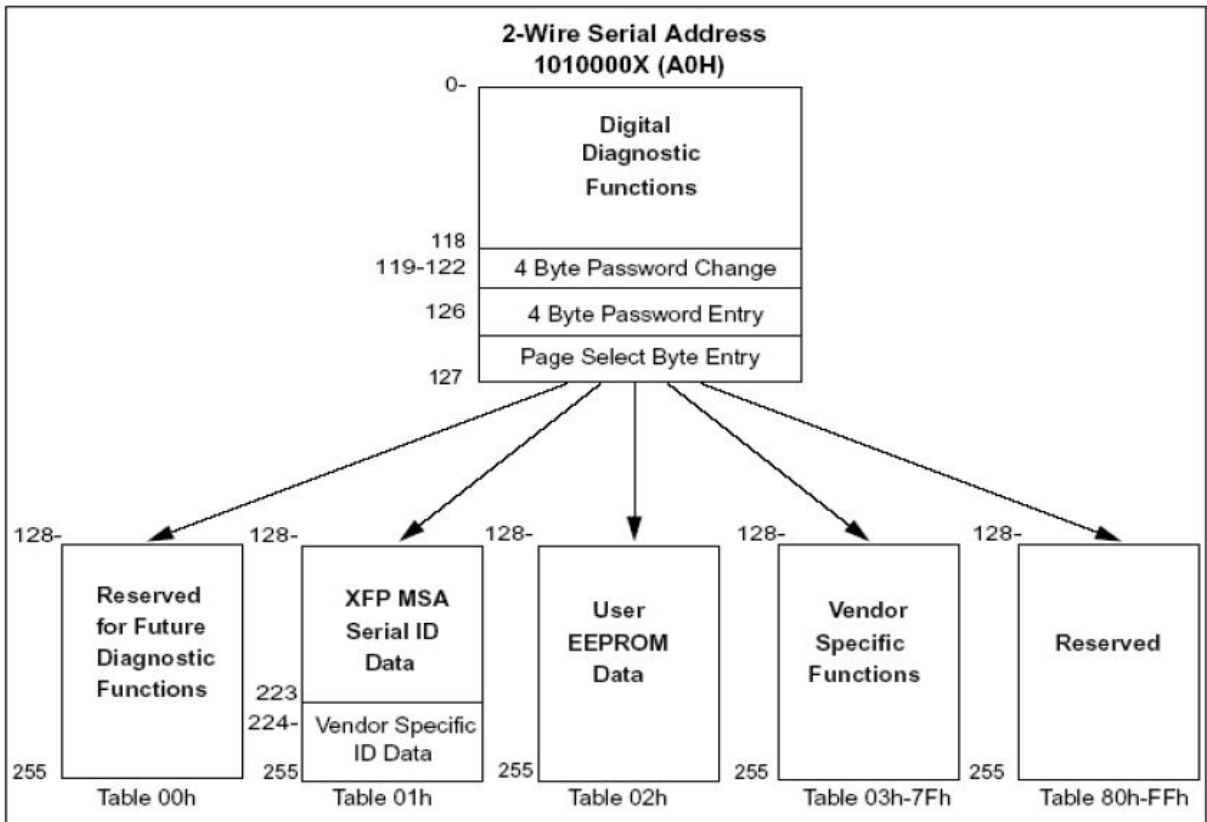

VI. Recommended Circuit

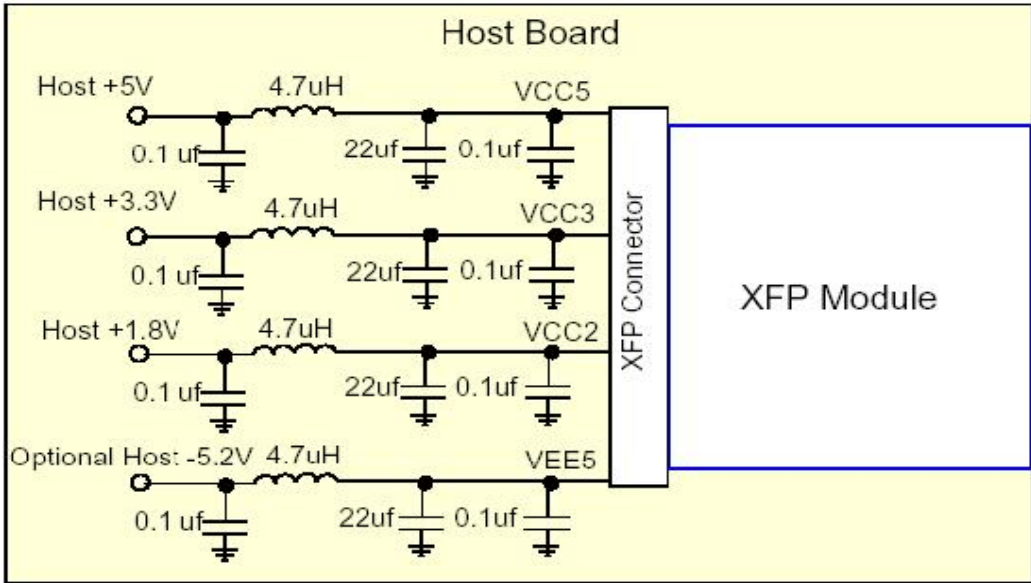

Recommended Host Board Power Supply Circuit

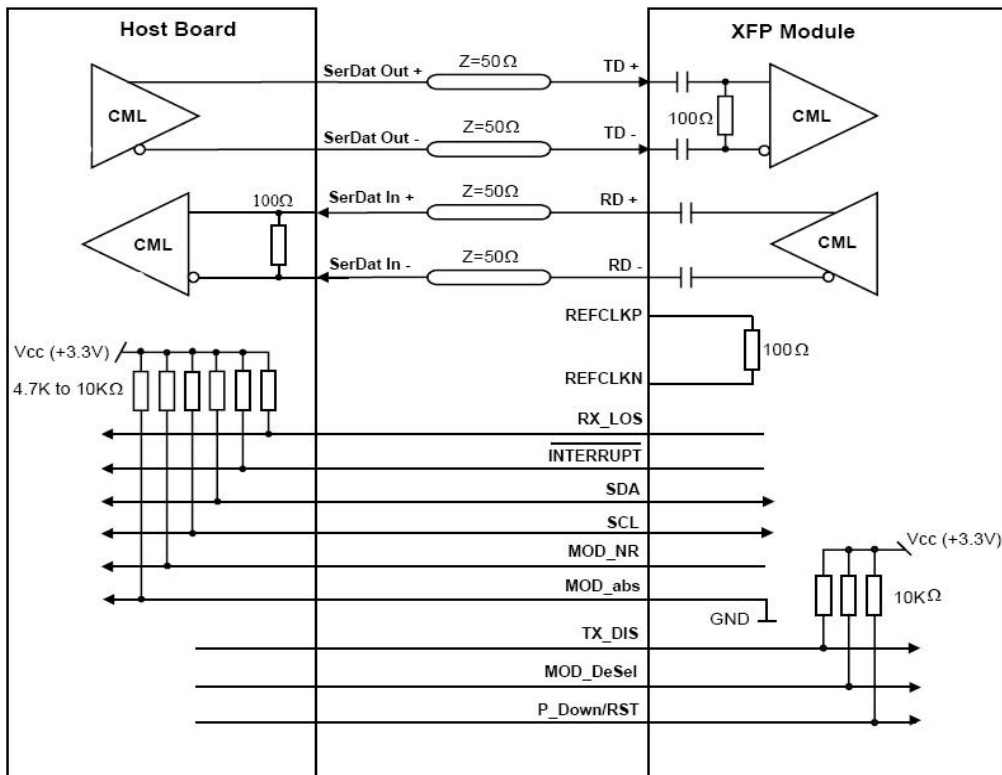

Recommended High-speed Interface Circuit

VII. Mechanical Dimensions

