

# 1000BASE-BX BiDi CSFP 1490nm-TX/1310nm-RX 10km DOM Transceiver

GLC-BX-D-LL



## Application

- Gigabit Ethernet(1000BASE-BX)
- Fiber Channel
- Point to Point FTTH Application
- Other optical transmission systems

## Features

- Support 1.25Gbps data links
- Hot-Pluggable
- LC connector
- Up to 10km on 9/125 $\mu$ m SMF
- 1490nm DFB laser transmitter
- 2XBi-directional transceivers in 1 SFP transceiver package
- Single +3.3V Power Supply
- Monitoring Interface Compliant with SFF-8472
- Operating temperature range:  
Commercial: 0° C to 70° C
- RoHS compliant and Lead Free

## Description

The CSFP transceivers are high performance, cost effective modules supporting 1.25Gbps and 10km transmission distance with SMF. Standard AC coupled CML for high speed signal and LVTTTL control and monitor signals.

This module is designed for Single-Mode single fiber, operates at the normal wavelength of TX1310nm/RX1490nm, 2channel. All modules satisfy class I laser safety requirements.

The transceivers are compatible with the Compact Small Form-Factor Pluggable (CSFP) Multi-Source Agreement (MSA) option 2, and SFF-8472.

For further information, please refer to CSFP MSA.

## Product Specifications

### I. Absolute Maximum Ratings

Parameter	Symbol	Min	Typ.	Max	Unit	Ref.
<b>Storage Temperature</b>	$T_S$	-40		85	°C	
<b>Supply Voltage</b>	$V_{CC}$	-0.5		4	V	
<b>Relative Humidity</b>	RH	0		85	%	

### II. Recommended Operating Environment

Parameter	Symbol	Min	Typ.	Max	Unit	Ref.
<b>Case operating Temperature</b>	$T_C$	0		+70	°C	
<b>Supply Voltage</b>	$V_{CC}$	3.135	3.30	3.465	V	
<b>Supply Current</b>	$I_{CC}$		300	450	mA	
<b>Inrush Current</b>	$I_{surge}$			$I_{CC}+30$	mA	
<b>Maximum Power</b>	$P_{max}$			1.5	W	

### III. Electrical Characteristics

Parameter	Symbol	Min	Typ.	Max	Unit	Ref.
<b>Transmitter</b>						
<b>Input differential impedance</b>	$R_{in}$	90	100	110	W	1
<b>Single ended data input swing</b>	$V_{in,PP}$	200		1200	mVp-p	
<b>Transmit Disable Voltage</b>	$V_D$	$V_{CC} - 1.3$		$V_{CC}$	V	2
<b>Transmit Enable Voltage</b>	$V_{EN}$	$V_{ee}$		$V_{ee} + 0.8$	V	
<b>Transmit Disable Assert Time</b>	$T_{dessert}$			10	us	
<b>Receiver</b>						
<b>Single ended data output swing</b>	$V_{out,pp}$	300		1000	mv	3
<b>LOS Fault</b>	$V_{losfault}$	$V_{CC} - 0.5$		$V_{CC\_host}$	V	5
<b>LOS Normal</b>	$V_{los\ norm}$	$V_{ee}$		$V_{ee} + 0.5$	V	5
<b>Power Supply Rejection</b>	PSR	100			mVpp	6

**Note:**

1. AC coupled.
2. Or open circuit.
3. Into 100 ohm differential termination.
4. 20 – 80 %
5. LOS is LVTTTL. Logic 0 indicates normal operation; logic 1 indicates no signal detected.
6. All transceiver specifications are compliant with a power supply sinusoidal modulation of 20 Hz to 1.5MHz up to specified value applied through the power supply filtering network shown on page 23 of the Small Form-factor Pluggable (SFP) Transceiver Multi-Source Agreement (MSA), September 14, 2000.

## IV. Optical Characteristics

Parameter	Symbol	Min	Typ.	Max	Unit	Ref.
-----------	--------	-----	------	-----	------	------

### Transmitter (Tx)

<b>Center Wavelength</b>	$\lambda_{CT}$	1470	1490	1510	nm	
<b>Spectral Width</b>	$\sigma$			3	nm	
<b>Side Mode Suppression Ratio</b>	SMSR	30			dB	
<b>Optical Output Power</b>	$P_{out}$	-9		-3	dBm	1
<b>Extinction Ratio</b>	ER	8.2			dB	
<b>Optical Rise/Fall Time</b>	$t_r / t_f$			260	ps	2
<b>Relative Intensity Noise</b>	RIN			-120	dB/Hz	

### Output Eye Mask

Compliant with Eye Mask Defined in IEEE 802.3 standard

### Receiver (Rx)

<b>Optical Input Wavelength</b>	$\lambda_{cR}$	1290	1310	1330	nm	
<b>Receiver Overload</b>	$P_{ol}$	-3			dBm	4
<b>RX Sensitivity</b>	$S_{en}$			-23	dBm	4
<b>RX_LOS Assert</b>	$LOS_A$	-35			dBm	
<b>RX_LOS De-assert</b>	$LOS_D$			-24	dBm	
<b>RX_LOS Hysteresis</b>	$LOS_H$	0.5			dB	

### General Specifications

<b>Data Rate</b>	BR		1.25		Gb/s	
<b>Bit Error Rate</b>	BER		$10^{-12}$			

**Max. Supported Link Length on 9/125µm SMF@1.25Gb/s**

$L_{MAX}$

20

km

**Total System Budget**

LB

14

dB

**Notes:**

1. The optical power is launched into SMF.
2. 20-80%.
3. Jitter measurements taken using Agilent OMNIBERT 718 in accordance with GR-253.
4. Measured with PRBS 2<sup>23</sup>-1 at 10<sup>-12</sup> BER

**V. Pin Assignment**

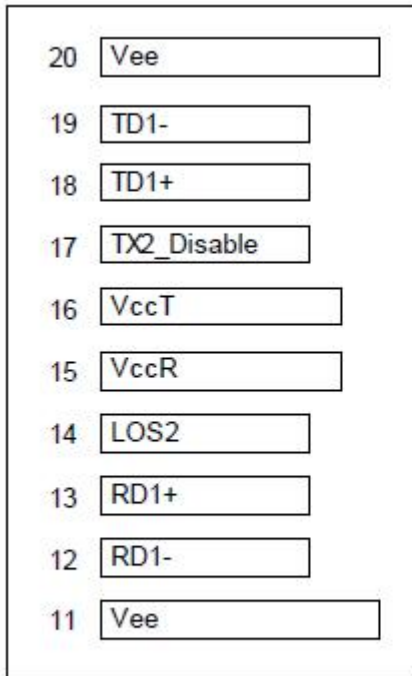

Top of Board

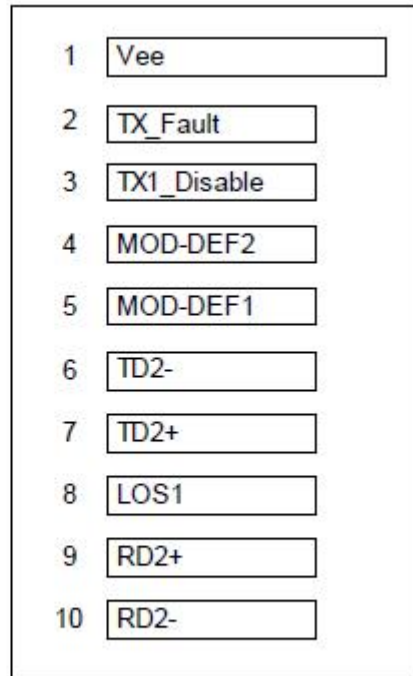

Bottom of Board  
(as view through top of board)

**2ch Compact SFP (Option 2) Electrical Pad Layout**

## VI.Pin Function Definitions

Pin	Name	Function	Notes
1	Vee	Ground	1
2	TX Fault	Transmitter Fault Indication	5
3	TX1 Disable	Transmitter disable control of Channel 1, high signal disables optical output of Channel 1	2
4	MOD-DEF2	I2C data (SDA)	3
5	MOD-DEF1	I2C clock (SCL)	3
6	TD2-	Inverted transmitter data input of Channel 2 (internally AC coupled)	6
7	TD2+	Non-inverted transmitter data input of Channel 2 (internally AC coupled)	6
8	LOS1	Open collector/drain output, high signal indicates los of signal in RX Channel 1	5
9	RD2+	Non-inverted receiver data output of Channel 2 (internally AC coupled)	6
10	RD2-	Inverted receiver data output of Channel 2 (internally AC coupled)	6
11	Vee	Ground	1
12	RD1-	Non-inverted receiver data output of Channel 1 (internally AC coupled)	6
13	RD1+	Inverted receiver data output of Channel 1 (internally AC coupled)	6
14	LOS2	Loss of Signal for channel 2	5
15	VccR	Receiver Power	1
16	VccT	Transmitter Power	1
17	TX2 Disable	Transmitter disable control of Channel 2, high signal disables optical output of Channel 2	6
18	TD1+	Non-inverted transmitter data input of Channel 1 (internally AC coupled)	6
19	TD1-	Inverted transmitter data input of Channel 1 (internally AC coupled)	6
20	Vee	Ground	1

**Notes:**

- 1.Circuit ground is internally isolated from chassis ground.
- 2.Laser output disabled on TDIS >2.0V or open, enabled on TDIS <0.8V.
- 3.Should be pulled up with 4.7k - 10 kΩ on host board to a voltage between 2.0V and 3.6V.MOD\_DEF(0) pulls line low to indicate module is plugged in.
- 4.Rate select is not used
- 5.LOS is open collector output. Should be pulled up with 4.7k – 10 kΩ on host board to a voltage between 2.0V and 3.6V. Logic 0 indicates normal operation; logic 1 indicates loss of signal.
- 6.AC Coupled

**VII.SFP Module EEPROM Information and Management**

The SFP modules implement the 2-wire serial communication protocol as defined in the SFP -8472.The serial ID information of the SFP modules and Digital Diagnostic Monitor parameters can be accessed through the I2C interface at address A0h and A2h.

The memory is mapped in Table 1.

Detailed ID information(A0h) is listed in Table 2.

And the DDM specification is at address A2h.

For more details of the memory map and byte definitions, please refer to the SFF-8472, “Digital Diagnostic Monitoring Interface for Optical Transceivers”.The DDM parameters have been internally calibrated.

**Table 1.** Digital Diagnostic Memory Map (Specific Data Field Descriptions)

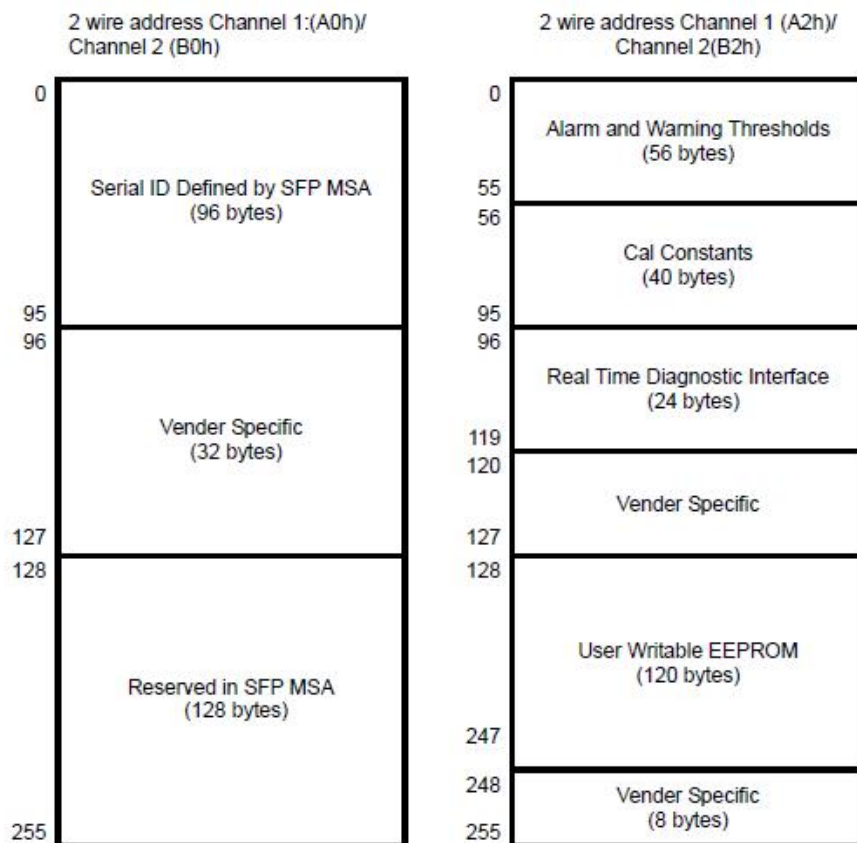

**Table 2.** EEPROM Serial ID Memory Contents (A0h)

Data Address	Length(Byte)	Name of Length	Description and Contents
Base ID Fields			
0	1	Identifier	Type of Serial transceiver (03h=SFP)
1	1	Reserved	Extended identifier of type serial transceiver (04h)
2	1	Connector	Code of optical connector type (07=LC)
3-10	8	Transceiver	
11	1	Encoding	NRZ(03h)
12	1	BR, Nominal	Nominal baud rate, unit of 100Mbps
13-14	2	Reserved	(0000h)
15	1	Length(9um)	Link length supported for 9/125um fiber, units of 100m
16	1	Length(50um)	Link length supported for 50/125um fiber, units of 10m
17	1	Length(62.5um)	Link length supported for 62.5/125um fiber, units of 10m
18	1	Length(Copper)	Link length supported for copper, units of meters
19	1	Reserved	
20-35	16	Vendor Name	SFP vendor name: Longline
36	1	Reserved	
37-39	3	Vendor OUI	SFP transceiver vendor OUI ID
40-55	16	Vendor PN	Part Number: "GLC-BX-D-LL-34" (ASCII)
56-59	4	Vendor rev	Revision level for part number
60-62	3	Reserved	
63	1	CCID	Least significant byte of sum of data in address 0-62



## Extended ID Fields

64-65	2	Option	Indicates which optical SFP signals are implemented(001Ah = LOS, TX_FAULT, TX_DISABLE all supported)
66	1	BR, max	Upper bit rate margin, units of %
67	1	BR, min	Lower bit rate margin, units of %
68-83	16	Vendor SN	Serial number (ASCII)
84-91	8	Date code	Longline's Manufacturing date code
92-94	3	Reserved	
95	1	CCEX	Check code for the extended ID Fields (addresses 64 to 94)

## Vendor Specific ID Fields

96-127	32	Readable	Longline specific date, read only
128-255	128	Reserved	Reserved for SFF-8079

**Table 3.** Diagnostics Memory Contents (A2h B2h)

Data Address	Length(Byte)	Name ofLength	Description and Contents
Diagnostic and control/status fields			
0-39	40	A/W Thresholds	Diagnostic Flag Alarm and Warning Thresholds
40-55	16	Unallocated	
56-91	16	Ext Cal Constants	Diagnostic calibration constants for optional External Calibration
92-94	3	Unallocated	
95	1	CC_DMI	Check code for Base Diagnostic Fields (addresses 0 to 94)
96-105	10	Diagnostics	Diagnostic Monitor Data (internally or externally calibrated)
106-109	4	Unallocated	
110	1	Status/Control	Optional Status and Control Bits
111	1	Reserved	Reserved for SFF-8079

112-113	2	Alarm Flags	Diagnostic Alarm Flag Status Bits
114-115	2	Unallocated	
116-117	2	Warning Flags	Diagnostic Warning Flag Status Bits
118-119	2	Ext Status/Control	Extended module control and status bytes
General use fields			
120-127	8	Vendor Specific	Vendor specific memory addresses
128-247	120	User EEPROM	User writable non-volatile memory
248-255	8	Vendor Control	Vendor specific control addresses

**Table 4.** Digital Diagnostics Monitor Characteristics

Data Address	Parameter	Accuracy	Unit
96-97	Transceiver Internal Temperature	± 3.0	° C
98-99	VCC3 Internal Supply Voltage	± 3.0	%
100-101	Laser Bias Current	± 10	%
102-103	Tx Output Power	± 3.0	dBm
104-105	Rx Input Power	± 3.0	dBm

## VI.Regulatory Compliance

The GLC-BX-D-LL-34 complies with international Electromagnetic Compatibility (EMC) and international safety requirements and standards (see details in Table following).

Electrostatic Discharge(ESD) to the Electrical Pins	MIL-STD-883E Method 3015.7	Class 1(>1000 V)
Electrostatic Discharge (ESD) to the Duplex LC Receptacle	IEC 61000-4-2GR-1089-CORE	Compatible with standards
Electromagnetic Interference (EMI)	FCC Part 15 Class B EN55022 Class B (CISPR 22)VCCI Class B	Compatible with standards
Laser Eye Safety	FDA 21CFR 1040.10 and 1040.11 EN60950, EN (IEC) 60825-1,2	Compatible with Class 1 laser product.

### VIII. Recommend Circuit

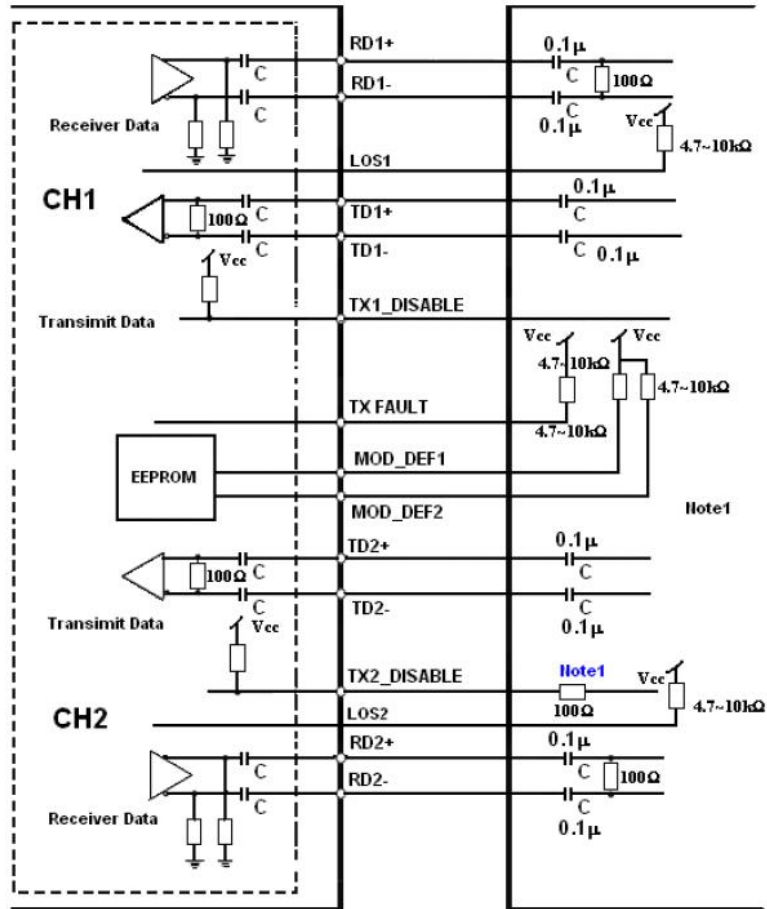

**Note1: Recommendation 100\_ series resistance on host board**