

100BASE-FX SFP 1310nm 2km DOM Industrial Transceiver

E1MG-100FX-LL



Application

- SONET OC-3/SDH STM-1
- Fast Ethernet
- Other Optical Links

Features

- Up to 155M b/s Data Links
- Hot-Pluggable
- 1310nm FP Laser Transmitter
- Duplex LC Connector
- RoHS Compliant and Lead Free
- Up to 2 km on 50/125 μ m MMF
- Single +3.3V Power Supply
- Monitoring Interface Compliant with SFF-8472
- Industrial Operating Temperature Range: -40°C to 85°C

Description

E1MG-100FX-LL Small Form Pluggable (SFP) modules are based on the SFP Multi Source Agreement (MSA). It is compliant with the Gigabit Ethernet and 100BASE-T standards as specified in IEEE 802.3U and GR-468.

Product Specifications

I. Absolute Maximum Ratings

Parameter	Symbol	Min	Typical	Max	Unit
Storage Temperature Range	T_s	-40		85	°C
Relative Humidity	RH	0		85	%
Supply Voltage	V_{cc}	-0.3		+4	V
Case Operating Temperature	Industrial	T_{op}	-40	85	°C

II. Recommended Operating Environment

Parameter	Symbol	Min	Typical	Max	Unit
Case Operating Temperature	Industrial	T_c	-40	85	°C
Supply Voltage	$V_{CCT,R}$	3.0		3.6	V

III. Electrical Characteristics (T_{OP} = 0 to 70°C, V_{CC} = 3.00 to 3.60 Volts)

Parameter	Symbol	Min	Type	Max	Unit	Note
Supply Voltage	V _{CC}	3.0	3.30	3.60	V	
Supply Current	I _{CC}			300	mA	
Inrush Current	I _{surge}			I _{CC} +30	mA	
Maximum Power	P _{max}			1.0	W	

Transmitter Section

Input Differential Impedance	R _{in}	90	100	110	W	1
Single Ended Data Input Swing	V _{in PP}	200		1200	mVp-p	
Transmit Disable Voltage	V _D	V _{CC} - 1.3		V _{CC}	V	2
Transmit Enable Voltage	V _{EN}	V _{EE}		V _{EE} + 0.8	V	
Transmit Disable Assert Time	T _{dessert}			10	us	

Receiver Section

Single Ended Data Output Swing	V _{out,pp}	300		1000	mv	3
Data Output Rise Time	t _r			1300	ps	4
Data Output Fall Time	t _f			1300	ps	4
LOS Fault	V _{losfault}	V _{CC} - 0.5		V _{CC_host}	V	5
LOS Normal	V _{losnorm}	V _{EE}		V _{EE} +0.5	V	5
Power Supply Rejection	PSR	100			mVpp	6

Note:

1. AC coupled.
2. Or open circuit.
3. Into 100 ohm differential termination.
4. 20 – 80 %
5. LOS is LVTTTL. Logic 0 indicates normal operation; logic 1 indicates no signal detected.
6. All transceiver specifications are compliant with a power supply sinusoidal modulation of 20 Hz to 1.5MHz up to specified value applied through the power supply filtering network shown on page 23 of the Small Form-factor Pluggable (SFP) Transceiver Multi-Source Agreement (MSA), September 14, 2000.

IV. Optical Parameters ($T_{OP} = 0$ to 70°C , $V_{CC} = 3.00$ to 3.60 Volts)

Parameter	Symbol	Min	Type	Max	Unit	Note
-----------	--------	-----	------	-----	------	------

Transmitter Section

Center Wavelength	λ_c	1270	1310	1360	nm	1
Spectral Width	σ			3	nm	
Optical Output Power	P_{out}	-15		-8	dBm	2
Optical Rise/Fall Time	t_r / t_f			1300	ps	3
Extinction Ratio	ER	9.2			dB	

Eye Mask for Optical Output

Compliant with Eye Mask Defined in IEEE 802.3 standard

Receiver Section

Optical Input Wavelength	λ	1100		1670	nm	
Receiver Overload	P_{ol}			-3	dBm	4.5

Parameter	Symbol	Min	Type	Max	Unit	Note
RX Sensitivity	Sen			-32	dBm	4.5
RX_LOS Assert	LOS _A	-42			dBm	
RX_LOS Deassert	LOS _D			-33	dBm	
RX_LOS Hysteresis	LOS _H		2	2.5	dB	

General Specifications

Data Rate	BR		155		Mb/s	
Bit Error Rate	BER			10 ⁻¹²		
Max. Supported Link Length on 50/125µm MMF@155Mb/s	L _{MAX}		2		km	6
Total System Budget	LB	13			dB	7

Notes:

- Also specified to meet curves in FC-PI 13.0 Figures 18 and 19, which allow trade-off between wavelength spectral width.
- Class 1 Laser Safety per FDA/CDRH and EN (IEC) 60825 regulations.
- Unfiltered, 20-80%. Complies with IEEE 802.3 (Gig. E), FC 1x and 2x eye masks when filtered.
- Measured with conformance signals defined in FC-PI 13.0 specifications.
- Measured with PRBS 231-1 at 10-12 BER
- Dispersion limited per FC-PI Rev. 13
- Attenuation of 1dB/km is used for the link length calculations. Distances are indicative only. Please refer to the Optical Specifications in Table IV to calculate a more accurate link budget based on specific conditions in your application.

Digital Diagnostic Monitor Characteristics

The following digital diagnostic characteristics are defined over the Recommended Operating Environment unless otherwise specified. It is compliant to SFF8472 Rev10.2 with internal calibration mode. For external calibration mode please contact our account manager.

Parameter	Symbol	Min	Max	Unit
Temperature Monitor Absolute Error	DMI_Temp	-3	3	degC
Laser Power Monitor Absolute Error	DMI_TX	-3	3	dB
RX Power Monitor Absolute Error	DMI_RX	-3	3	dB
Supply Voltage Monitor Absolute Error	DMI_VCC	-0.1	0.1	V
Bias Current Monitor Absolute Error	DMI_Ibias	-10%	10%	mA

Block Diagram Definitions of Transceiver

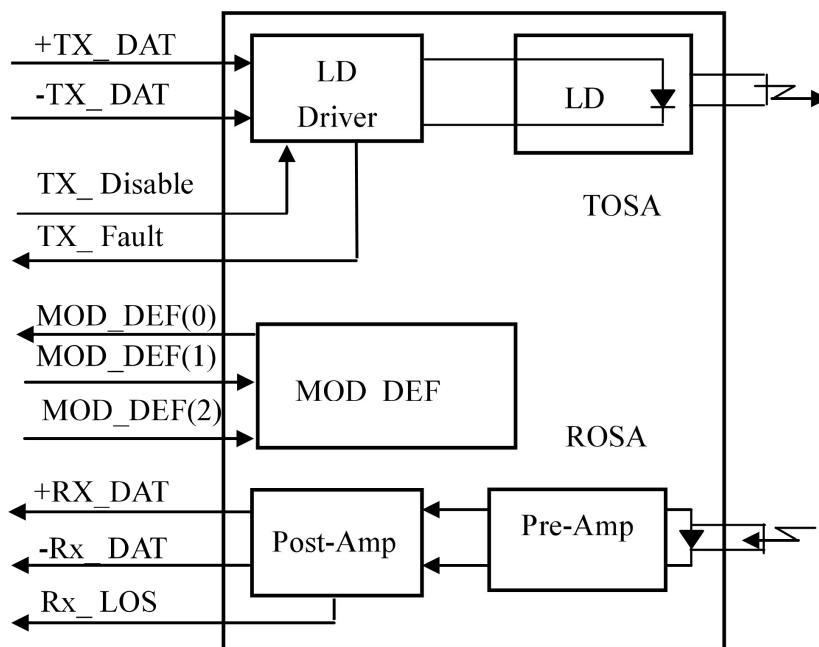

Figure1. Block Diagram

Pin Assignment

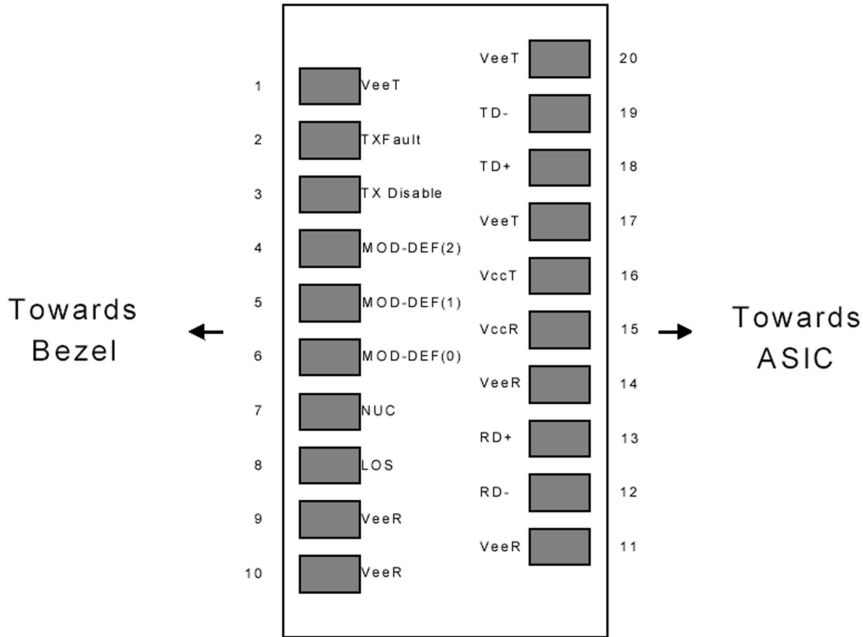

Figure 2. Diagram of Host Board Connector Block Pin Numbers and Names

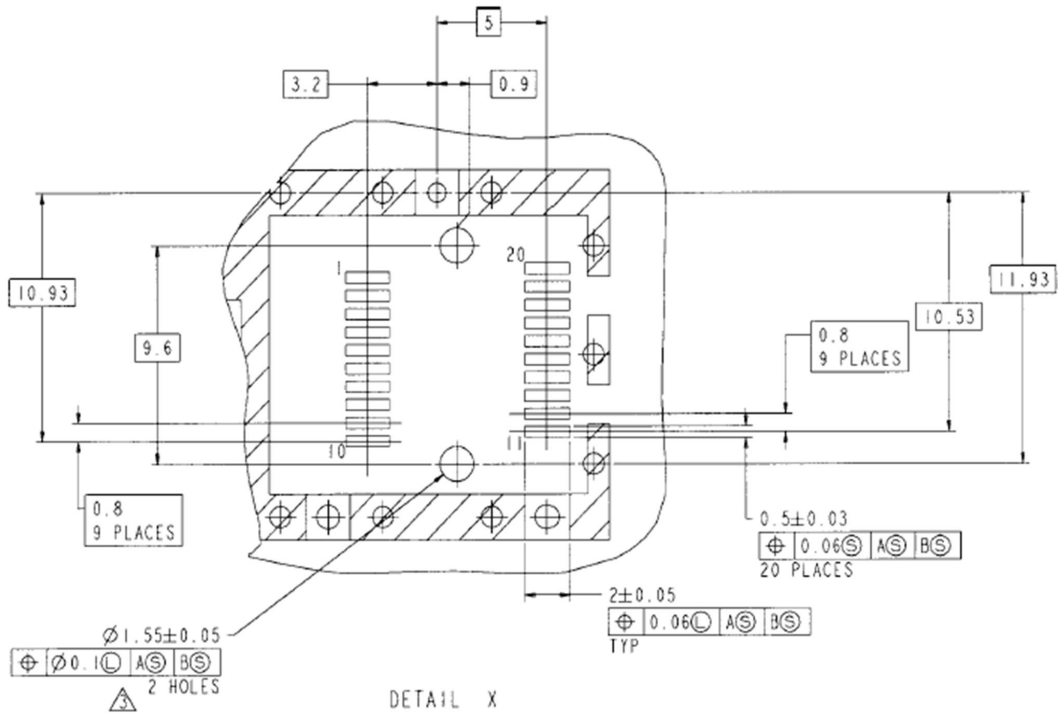

Figure 3. SFP Host Board Mechanical Layout

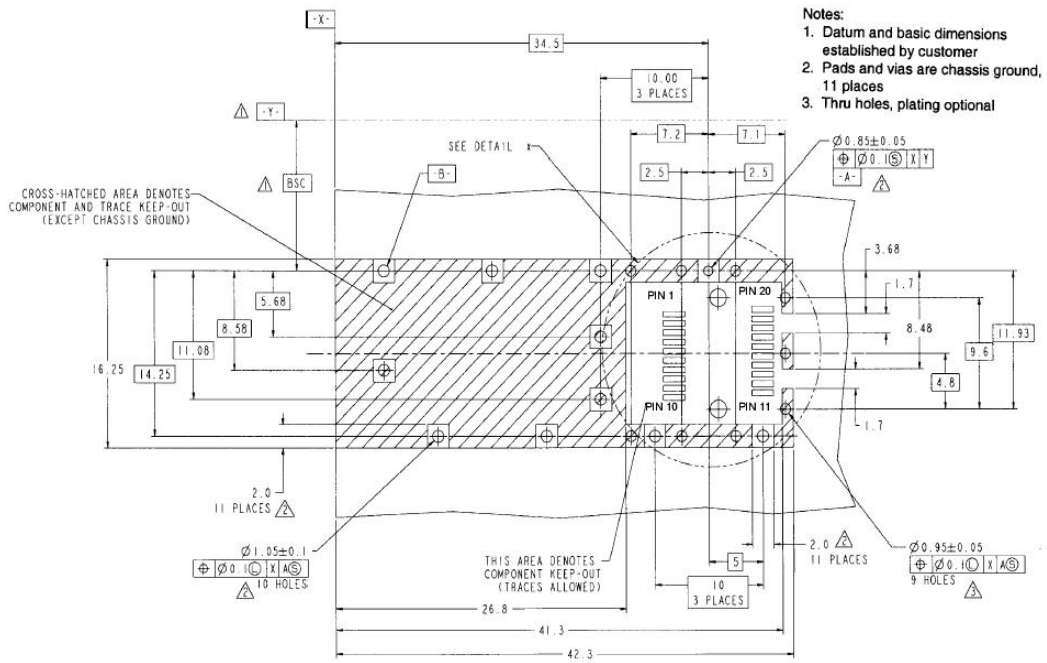

Figure 4. SFP Host Board Mechanical Layout(Cont)

Pin Description

Pin No	Name	Function	Plug Seq	Notes
1	VeeT	Transmitter Ground	1	1
2	TX Fault	Transmitter Fault Indication	3	
3	TX Disable	Transmitter Disable	3	2
4	MOD-DEF2	Module Definition	2	3
5	MOD-DEF1	Module Definition 1	3	3
6	MOD-DEF0	Module Definition 0	3	3
7	Rate Select	Not Connected	3	4

Pin No	Name	Function	Plug Seq	Notes
8	LOS	Loss of Signal	3	5
9	VeeR	Receiver Ground	1	1
10	VeeR	Receiver Ground	1	1
11	VeeR	Receiver Ground		1
12	RD-	Inv. Received Data Out	3	6
13	RD+	Received Data Out	3	6
14	VeeR	Receiver Ground	3	1
15	VccR	Receiver Power	2	1
16	VccT	Transmitter Power	2	
17	VeeT	Transmitter Ground	1	
18	TD+	Transmit Data In	3	6
19	TD-	Inv. Transmit In	3	6
20	VeeT	Transmitter Ground	1	

Notes:

1. Circuit ground is internally isolated from chassis ground.
2. Laser output disabled on TDIS >2.0V or open, enabled on TDIS <0.8V.
3. Should be pulled up with 4.7k - 10 kohms on host board to a voltage between 2.0V and 3.6V. MOD_DEF(0) pulls line low to indicate module is plugged in.
4. Rate select is not used
5. LOS is open collector output. Should be pulled up with 4.7k – 10 kohms on host board to a voltage between 2.0V and 3.6V. Logic 0 indicates normal operation; logic 1 indicates loss of signal.
6. AC Coupled

Recommended Circuit

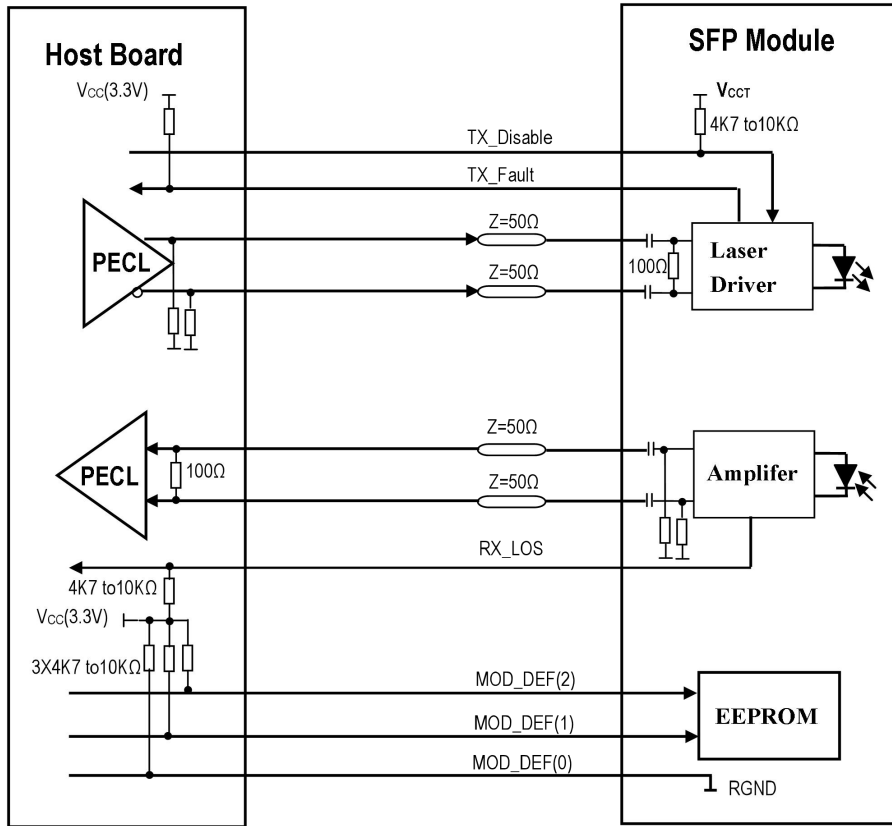

Figure 5. SFP Host Recommended Circuit

Serial ID Memory Contents

Data Address	Length (Byte)	Name of Length	Description and Contents
Base ID Fields			
0	1	Identifier	Type of Serial transceiver (03h=SFP)
1	1	Reserved	Extended identifier of type serial transceiver (04h)
2	1	Connector	Code of optical connector type (07=LC)
3-10	8	Transceiver	SONET

Data Address	Length (Byte)	Name of Length	Description and Contents
11	1	Encoding	SONET Scrambled
12	1	BR,Nominal	Nominal baud rate, unit of 100Mbps
13	1	Reserved	(0000h)
14	1	Length(9um,km)	Link length supported for 9/125um fiber, units of km
15	1	Length(9um)	Link length supported for 9/125um fiber, units of 100m
16	1	Length(50um)	Link length supported for 50/125um fiber, units of 10m
17	1	Length(62.5um)	Link length supported for 62.5/125um fiber, units of 10m
18	1	Length(Copper)	Link length supported for copper, units of meters
19	1	Reserved	
20-35	16	Vendor Name	SFP vendor name:Longline
36	1	Reserved	
37-39	3	Vendor OUI	SFP transceiver vendor OUI ID
40-55	16	Vendor PN	Part Number:SFP-100FX-31-LL
56-59	4	Vendor rev	Revision level for part number
60-61	2	Wavelength	Laser wavelength
62	1	Reserved	
63	1	CCID	Least significant byte of sum of data in address 0-62

Data Address	Length (Byte)	Name of Length	Description and Contents
--------------	---------------	----------------	--------------------------

Extended ID Fields

64-65	2	Option	Indicates which optical SFP signals are implemented(001Ah = LOS, TX_FAULT, TX_DISABLE all supported)
66	1	BR, max	Upper bit rate margin, units of %
67	1	BR, min	Lower bit rate margin, units of %
68-83	16	Vendor SN	Serial number (ASCII)
84-91	8	Date code	Manufacturing date code
92	1	Diagnostic Type	Diagnostics
93	1	Enhanced Options	Diagnostics
94	1	SFF-8472	Diagnostics
95	1	CCEX	Check code for the extended ID Fields (addresses 64 to 94)

Vendor Specific ID Fields

96-127	32	Readable	Vendor specific date, read only
---------------	----	----------	---------------------------------

Diagnostics Memory Contents (A2h)

Data Address	Length (Byte)	Name of Length	Description and Contents
Diagnostic and Control/Status Fields			
0-39	40	A/W Thresholds	Diagnostic Flag Alarm and Warning Thresholds
40-55	16	Unallocated	
56-91	16	Ext Cal Constants	Diagnostic calibration constants for optional External Calibration
92-94	3	Unallocated	
95	1	CC_DMI	Check code for Base Diagnostic Fields (addresses 0 to 94)
96-105	10	Diagnostics	Diagnostic Monitor Data (internally or externally calibrated)
106-109	4	Unallocated	
110	1	Status/Control	Optional Status and Control Bits
111	1	Reserved	Reserved for SFF-8079
112-113	2	Alarm Flags	Diagnostic Alarm Flag Status Bits
114-115	2	Unallocated	
116-117	2	Warning Flags	Diagnostic Warning Flag Status Bits
118-119	2	Ext Status/Control	Extended module control and status bytes

Data Address	Length (Byte)	Name of Length	Description and Contents
--------------	---------------	----------------	--------------------------

General Use Fields

120-127	8	Vendor Specific	Vendor specific memory addresses
128-247	120	User EEPROM	User writable non-volatile memory
248-255	8	Vendor Control	Vendor specific control addresses

References

1. Small Form-factor Pluggable (SFP) Transceiver Multi-source Agreement (MSA) September 14, 2000.
2. Bellcore GR-253 and ITU-T G.957 Specifications.

Mechanical Dimensions

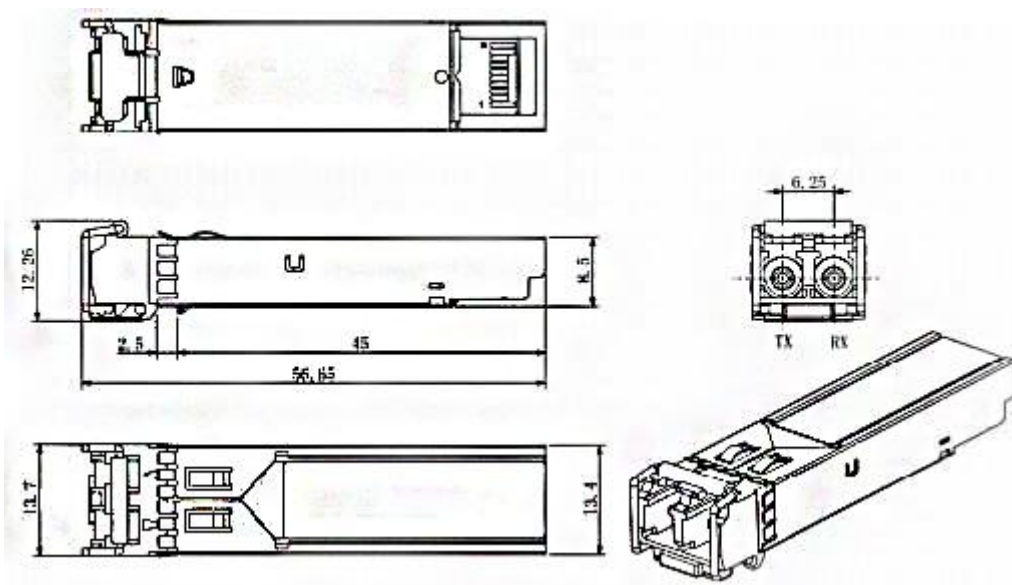

Figure 6. Mechanical Drawing