

# 25GBASE-SR SFP28 850nm 100m Industrial DOM Transceiver

407-BBWK-I-LL



## Application

- 25GBASE-SR Ethernet

## Standards

- SFF-8472
- SFF-8024
- SFF-8431
- SFF-8432

## Features

- Supports 25.78Gb/s Bit Rate
- Hot-pluggable SFP+ Footprint
- 850nm VCSEL Laser and PIN Photo-detector
- Internal CDR on Transmitter and Receiver Channel
- RoHS-10 Compliant
- Link Lengths at 25.78G 100m Over OM4 MMF
- LC Duplex Connector
- Low Power Consumption < 1W
- -40°C to 85°C Operating Temperature Range
- Single +3.3V±5% Power Supply
- Programmable TX Input Equalizer
- Programmable RX Pre-emphasis
- Digital Monitoring SFF-8472 Compliant

## Description

The 25G SR-I short-wavelength transceiver is designed for use in 25.78Gb/s data rate over multimode fiber. The transceiver is compliant with SFF-8431, and the mechanical SFP+ plug is compatible with SFF-8432. Digital diagnostics functions are available via a 2-wire serial interface, as specified in SFF-8472.

## Product Specifications

### I. Absolute Maximum Ratings

Parameter	Symbol	Min.	Max.	Unit
Supply Voltage	V <sub>cc</sub>	-0.3	+4.0	V
Storage Temperature	T <sub>s</sub>	-40	+85	°C
Operating Humidity	RH	0	+85	%

### II. General Specifications

Parameter	Symbol	Min.	Typ.	Max.	Unit
Bit Rate	BR		25.78		Gbps
Bit Error Ratio	BER			5*10 <sup>E-5</sup>	
Max. Supported Link Length	L <sub>MAX</sub>			100	m

### III. Recommended Operating Conditions

Parameter	Symbol	Min.	Typ.	Max.	Unit
Operating Temperature	T <sub>c</sub>	-40		+85	°C
Power Supply Voltage	V <sub>cc</sub>	3.14	3.3	3.46	V
Bit Rate	BR		25.78		Gbps
Max. Supported Link Length	L <sub>MAX</sub>			100	m

## IV. Electrical Characteristics

Parameter	Symbol	Min.	Typ.	Max.	Unit	Note
<b>Supply Voltage</b>	$V_{CC}$	3.14	3.3	3.46	V	
<b>Supply Current</b>	$I_{CC}$			230	mA	
<b>Transmitter</b>						
<b>Input Differential Impedance</b>	$R_{IN}$	80	100	120	$\Omega$	1
<b>Single Ended Data Input Swing</b>	$V_{IN}$	90		500	mVp-p	
<b>Transmit Disable Voltage</b>	$V_{DIS}$	2		$V_{CCHOST}$	V	
<b>Transmit Enable Voltage</b>	$V_{EN}$	$V_{EE}$		$V_{EE}+0.8$	V	
<b>Transmit Fault Assert Voltage</b>	$V_{FA}$	2		$V_{CCHOST}$	V	
<b>Transmit Fault De-Assert Voltage</b>	$V_{FDA}$	$V_{EE}$		$V_{EE}+0.8$	V	
<b>Receiver</b>						
<b>Single Ended Data Output Swing</b>	$V_{OD}$	200		500	mVp-p	
<b>LOS Fault</b>	$V_{LOSFT}$	2		$V_{CCHOST}$	V	
<b>LOS Normal</b>	$V_{LOSNR}$	$V_{EE}$		$V_{EE}+0.8$	V	

### Notes:

1. Differential between TD+ / TD-.

## V. Optical Characteristics

Parameter	Symbol	Min.	Typ.	Max.	Unit	Note
<b>Transmitter</b>						
<b>Nominal Wavelength</b>	$\lambda$	840		860	nm	
<b>Spectral Width</b>	$\Delta\lambda$			0.6	nm	
<b>Optical Modulation Amplitude</b>	POMA	-6.4		3	dBm	
<b>Optical Output Power</b>	$P_{av}$	-8.4		2.4	dBm	
<b>Extinction Ratio</b>	ER	2			dB	
<b>Transmitter and Dispersion Penalty</b>	TDP			5	dB	
<b>Average Launch Power of OFF Transmitter</b>	$P_{OFF}$			-30	dBm	
<b>Receiver</b>						
<b>Center Wavelength</b>	$\lambda$	840		860	nm	
<b>Average Receiver Power</b>	$P_{AVG}$	-10.3		2.4	dBm	1
<b>Stressed Receiver Sensitivity (OMA)</b>	$R_{SENSE}$			-5.2	dBm	2
<b>Receiver Reflectance</b>	$R_{REFL}$			-12	dB	
<b>Assert LOS</b>	$LOS_A$	-30			dBm	
<b>De-Assert LOS</b>	$LOS_D$			-13	dBm	
<b>LOS Hysteresis</b>		0.5			dB	

### Notes:

- Sensitivity for 25.78G PRBS 231-1 and BER better than or equal to  $5 \cdot 10^{-5}$ .
- The stressed sensitivity values in the table are for system level BER measurements which include the effects of CDR circuit.

## VI. Pin Assignment

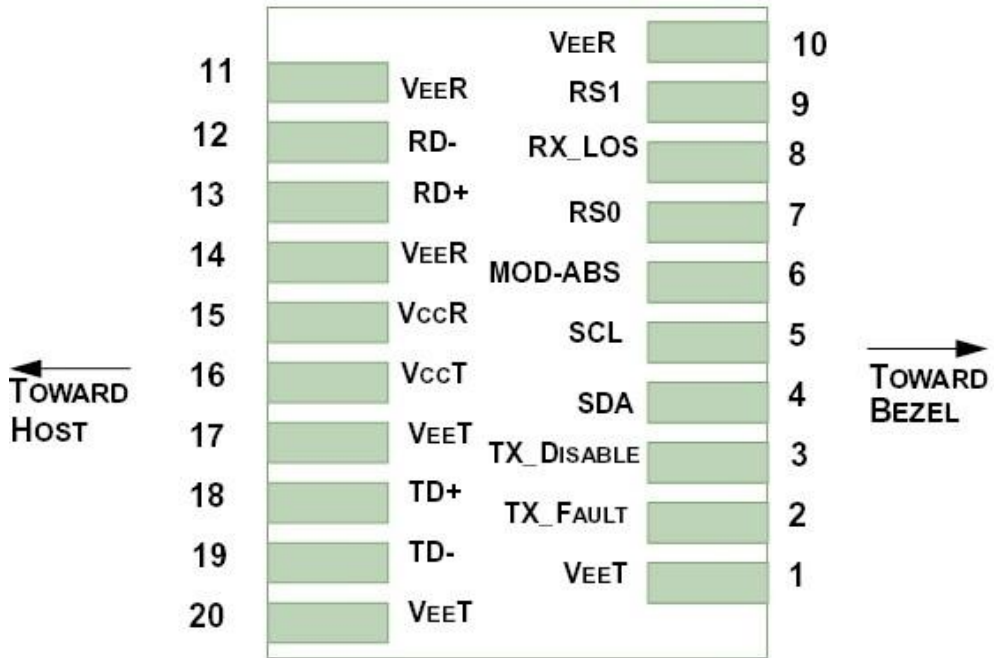

Pin Number	Symbol	Name	Description
<b>1,17,20</b>	VeeT	Transmitter Signal Ground	These pins should be connected to signal ground on the host board.
<b>2</b>	TX Fault	Transmitter Fault Out (OC)	Logic "1" Output = Transmitter Fault Logic "0" Output = Normal Operation This pin is open collector compatible, and should be pulled up to Host Vcc with a 10kΩ resistor.
<b>3</b>	TX Disable	Transmitter Disable In (LVTTTL)	Logic "1" Input (or no connection) = Laser off Logic "0" Input = Laser on This pin is internally pulled up to VccT with a 10 kΩ resistor.
<b>4</b>	SDA	Module Definition Identifiers	Serial ID with SFF 8472 Diagnostics Module Definition pins should be pulled up to Host Vcc with 10 kΩ resistors.
<b>5</b>	SCL		
<b>6</b>	MOD-ABS		
<b>7</b>	RS0	Receiver Rate Select (LVTTTL) Transmitter Rate Select (LVTTTL)	NA
<b>9</b>	RS1		NA
<b>8</b>	LOS	Loss of Signal Out (OC)	This pin is open collector compatible, and should be pulled up to Host Vcc with a 10kΩ resistor.
<b>10,11,14</b>	VeeR	Receiver Signal Ground	These pins should be connected to signal ground on the host board.
<b>12</b>	RD-	Receiver Negative DATA Out (CML)	Light on = Logic "0" Output Receiver DATA output is internally AC coupled and series terminated with a 50Ω resistor.
<b>13</b>	RD+	Receiver Positive DATA Out(CML)	Light on = Logic "1" Output Receiver DATA output is internally AC coupled and series terminated with a 50Ω resistor.
<b>15</b>	VccR	Receiver Power Supply	This pin should be connected to a filtered +3.3V power supply on the host board. See Figure 3.Recommended power supply filter
<b>16</b>	VccT	Transmitter Power Supply	This pin should be connected to a filtered +3.3V power supply on the host board. See Figure 3.Recommended power supply filter
<b>18</b>	TD+	Transmitter Positive DATA In(CML)	Logic "1" Input = Light on Transmitter DATA inputs are internally AC coupled and terminated with a differential 100Ω resistor.
<b>19</b>	TD-	Transmitter Negative DATA In(CML)	Logic "0" Input = Light on Transmitter DATA inputs are internally AC coupled and terminated with a differential 100Ω resistor.

## VII. Optical Module Block Diagram

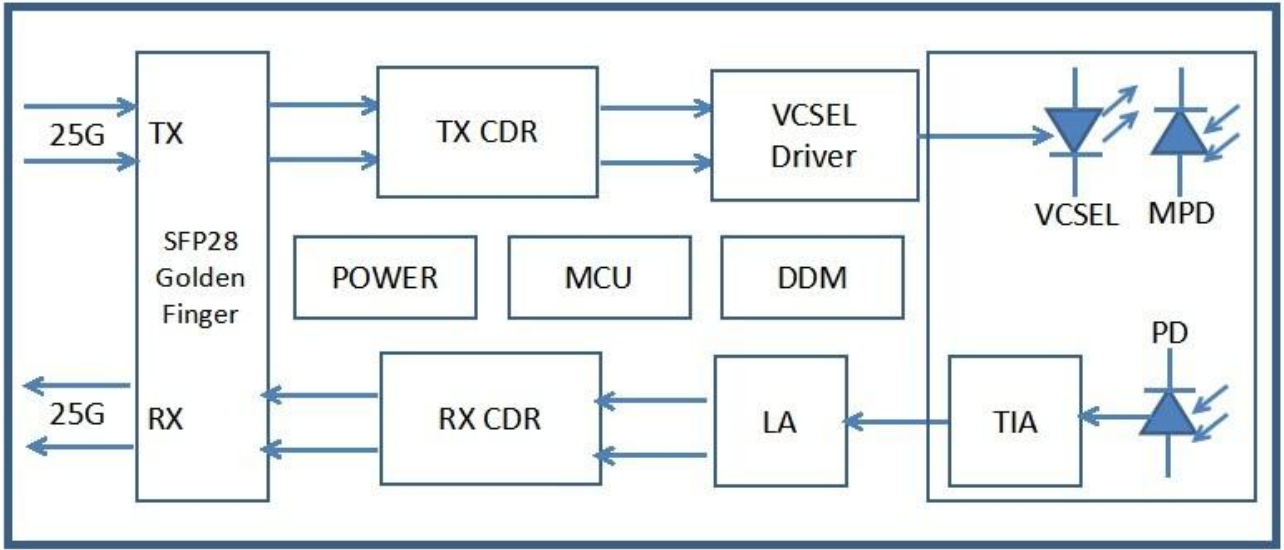

## VIII. Regulatory Compliance

Feature	Test Method	Performance
<b>Electrostatic Discharge (ESD) to the Electrical Pins</b>	MIL-STD-883C Method 3015.7	Class 1 (> 1500 Volts)
<b>Electrostatic Discharge (ESD) Immunity</b>	Variation of IEC 61000-4-2	LV 4 (Air discharge : 15KV; Contact discharge: 8 KV)
<b>Electromagnetic Interference (EMI)</b>	CISPR22 ITE Class B EN55022 Class B FCC Class B	Compliant with standards
<b>Immunity</b>	IEC61000-4-3 Class 2 EN55024	Typically show no measurable effect from a 3V/m fieldswept from 80 to 1000MHz applied to the transceiver without a chassis enclosure

### IX. Typical Application Circuit

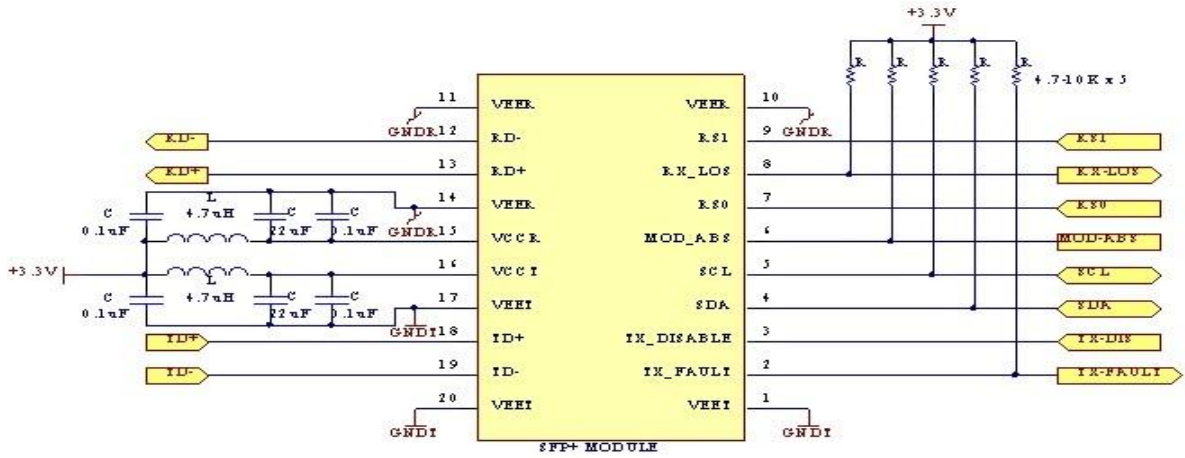

### X. Diagram Mechanical Drawing

