

25GBASE-BX 1270nmTX/1310nmRX 40km DOM Transceiver

25GB-BX-U4-LL



Application

- 25GE ER Lite
- eCPRI & CPRI

Features

- UP to 25.78Gb/s bi-directional data links
- Hot-Pluggable SFP28 footprints
- Simplex LC connector
- 1271nm DFB laser transmitter for -2731
- Up to 30km on 9/125m SMF without FEC
- Up to 40km on 9/125m SMF with FEC
- 2-wire interface for management specifications compliant with SFF 8472 digital diagnostic monitoring interface for optical transceivers
- Power Supply :+3.3V
- Operating case temperature Range: Commercial: 0~ 70° C
- RoHS compliant

Description

Longline's SFP28 transceivers are designed for use in Ethernet links up to 25.78Gb/s data rate and up to 30 km link length. They are compliant SFF-8472, and compatible with SFF-8432 and applicable portions of SFF-8431. The product is RoHS compliant and lead-free per Directive 2011/96/EU.

I. Pin Function Definitions

Pin No.	Name	Function	Notes
1	VeeT	Module transmitter ground	1
2	Fault	Module transmitter Fault	2
3	Disable	Transmitter Disable; Turns off transmitter laser output	3
4	SDL	2 wire serial interface data input/output (SDA)	4
5	SCL	2 wire serial interface clock input (SCL)	4
6	MOD-ABS	Module Absent, connect to VeeR or VeeT in the module	2
7	RS0	Rate select0: module inputs and are pulled low to VeeT with >30 kΩ resistors in the module.	
8	LOS	Receiver Loss of Signal Indication	RX_LOSS
9	RS1	Rate select1: module inputs and are pulled low to VeeT with >30 kΩ resistors in the module.	
10	VeeR	Module receiver ground	1
11	VeeR	Module receiver ground	1
12	RD	Receiver inverted data out put	
13	RD+	Receiver non-inverted data out put	
14	VeeR	Module receiver ground	1
15	VccR	Module receiver 3.3V supply	
16	VccT	Module transmitter 3.3V supply	
17	VeeT	Module transmitter ground	1
18	TD+	Transmitter non-inverted data out put	
19	TD	Transmitter inverted data out put	
20	VeeT	Module transmitter ground	1

Notes:

1. The module ground pins shall be isolated from the module case.
2. This pin is an open collector/drain output pin and shall be pulled up with 4.7K-10Kohms to Host_Vcc on the host board.
3. This pin shall be pulled up with 4.7K-10Kohms to VccT in the module.
4. This pin is an open collector/drain output pin and shall be pulled up with 4.7K-10Kohms to Host_Vcc on the host board.

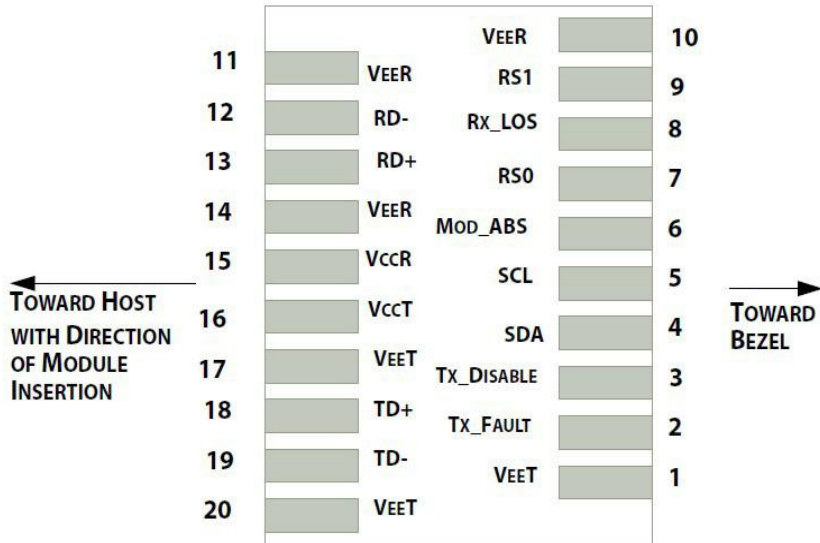

II. Absolute Maximum Ratings

Parameter	Symbol	Min	Typical	Max	Unit	Note
Storage Temperature	TS	-40		+85	° C	
Case Operating Temperature	TA	0		+70	° C	Commercial
		-5		+85	° C	Extended
		-40		+85	° C	Industrial
Maximum Supply Voltage	Vcc	0		3.6	V	
Relative Humidity(Non-condensing)	RH	0		85	%	

III. Electrical Characteristics ($T_{OP} = -40$ to 85 ° C, $V_{CC} = 3.15$ to 3.46 Volts)

Parameter	Symbol	Min	Typical	Max.	Unit	Note
Supply Voltage	V_{CC}	3.14		3.46	V	
Supply Current	I_{CC}			360	mA	Commercial
				430	mA	Extended
				430	mA	Industrial
Power Consumption	p			1.2	W	Commercial
				1.4	W	Extended
				1.4	W	Industrial
Data Rate	R		25.8		Gb/s	
Fiber Length	L			30	KM	

Transmitter Section:

Input Differential Impedance	R_{in}		100		Ω	1
Differential Input Voltage Swing	$V_{in,pp}$	180		450	mV	2
Transmit Disable Voltage	V_D	2		V_{CC}	V	3
Transmit Enable Voltage	V_{EN}	V_{EE}		$V_{EE}+0.8$	V	

Receiver Section:

Single Ended Output Voltage Tolerance	V	-0.3		4	V	
Rx Output Diff Voltage	V_o	180		450	mV	
LOS Fault	$V_{LOS\ fault}$	2		$V_{CC_{HOST}}$	V	4
LOS Normal	$V_{LOS\ norm}$	V_{EE}		$V_{EE}+0.8$	V	4

Notes:

1. Connected directly to TX data input pins. AC coupling from pins into laser driver IC.
2. Per SFF-8431 Rev 3.0
3. Into 100 ohms differential termination.
4. LOS is an open collector output. Should be pulled up with 4.7k – 10kΩ on the host board. Normal operation is logic 0; loss of signal is logic 1. Maximum pull-up voltage is 5.5V.

IV. Optical Characteristics (T_{OP} = -40 to 85 ° C, VCC = 3.15 to 3.46 Volts)

Parameter	Symbol	Min	Typical	Max.	Unit	Note
-----------	--------	-----	---------	------	------	------

Transmitter Section:

Center Wavelength	λ_t	1265	1271	1277	nm	
Spectral Width(-20dB)	$\Delta\lambda$			1	nm	
Average Optical Power	Pavg	0		+6	dBm	1
Laser Off Power	Poff			-30	dBm	
Side Mode Suppression Ratio		30				
Extinction Ratio	ER	3.5		1.4	dB	1
Optical Return Loss Tolerance				-12	dB	

Receiver Section:

Center Wavelength	λ_r	1305	1311	1317	nm	
Receiver Sensitivity				-18	dBm	2
Los Assert	LOSA	-30			dBm	3
Los Dessert	LOSD			-19	dBm	
Los Hysteresis	LOSH	0.5			dB	
Overload		2			dBm	

Notes:

1. Average power figures are informative only, per IEEE802.3cc.
2. Receiver sensitivity is informative. Shall be measured with conformance test signal for . BER = 5x 10⁻⁵ .

V. Timing Characteristics

Parameter	Symbol	Min	Typical	Max.	Unit
TX_Disable Assert Time	T_off			100	us
TX_Disable Negate Time	T_on			2	ms
Time to Initialize 2-wire interface	T_2w_start_up			300	ms
Time to Initialize	T_start_up	0		300	ms
Time to Initialize Cooled Module and Time to Power Up a Cooled Module to Power Level II	T_start_up_cooled			90	s
Time to Power Up to Level II	T_power_level2	30		300	ms
Time to Power Down from Level II	T_power_down	3.5		300	ms
Tx_Fault assert	Tx_Fault_on			1	ms
Tx_Fault Assert for Cooled Module	Tx_Fault_on_cooled			50	ms
TX_FAULT Reset	T_reset	10			us
Rx_LOS Assert Delay	T_los_on			100	us
Rx_LOS Negate Delay	T_los_off			100	us

VI. Digital Diagnostic Specifications

Parameter	Symbol	Units	Min	Max.	Accuracy	Note
Transceiver Temperature	DDDTemp	°C	-40	+85	±5°C	Industrial
			-5	+85	±5°C	Extended
			0	+70	±5°C	Commercial
Transceiver Supply Voltage	DDDVoltage	V	3.15	3.45	±3%	
Transmitter Bias Current	DDDBias	mA	0	35	±10%	
Transmitter Output Power	DDDTx-Power	dBm	-5	+5	±3dB	
Receiver Average Optical Input Power	DDDRx-Power	dBm	-16	-3	±3dB	

VII. Transceiver Block Diagram

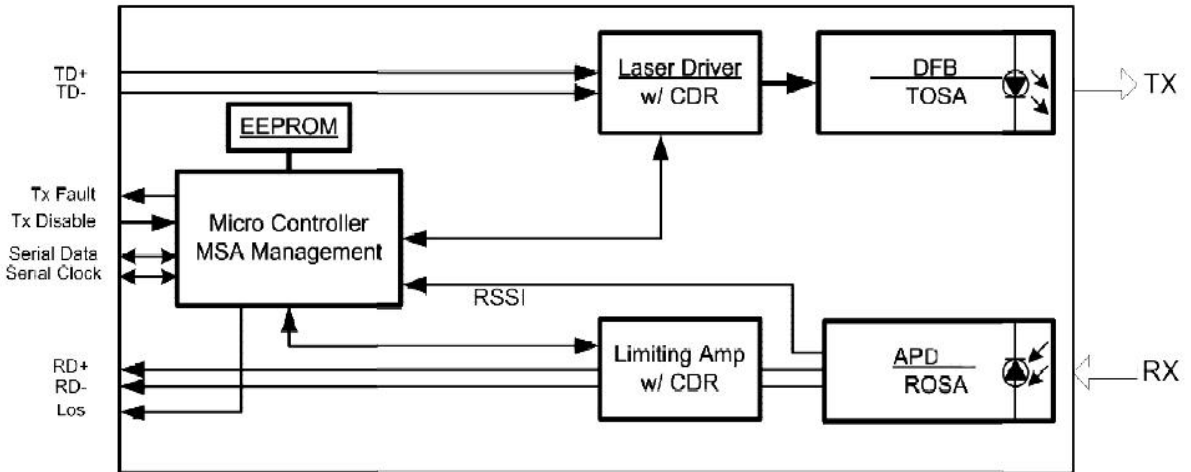

Recommended Circuit:

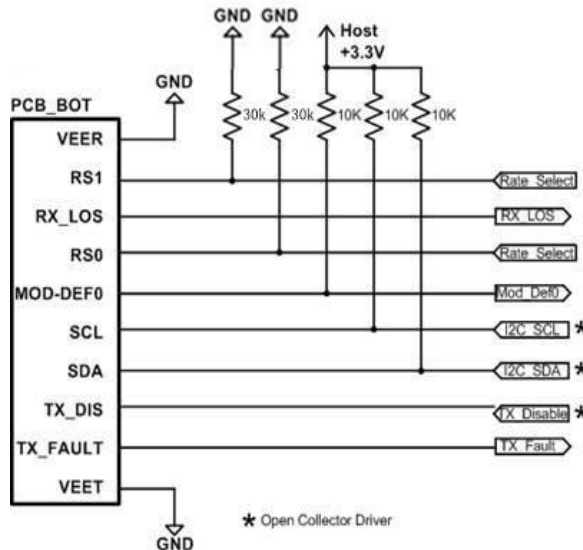
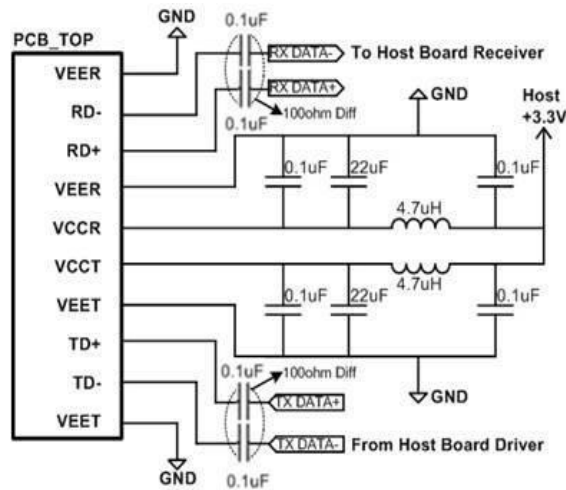

Mechanical Dimensions:

