

25GBASE-LR SFP28 1310nm 10km Industrial DOM Transceiver

25G-SFP28-LR-I-LL



Application

- 25GBASE-LR
- CPRI Option 10/e CPRI

Standards

- SFF-8472
- SFF-8402
- SFF-8432
- SFF-8431
- CEI-28G-VSR

Features

- Up to 10 km Transmission Distance
- Low Power Consumption <1.2W
- Single 3.3V ± 5% Power Supply
- LC-duplex Connector
- -40°C to 85°C Operating Case Temperature Range
- Compliant with SFF-8472

Description

25G LR-I is a 1310nm DFB laser based 25Gb/s SFP28 transceiver. It is designed to transmit and receive optical data up to 10km over single mode fiber. The transceiver is compliant with SFF-8472, SFF-8402, SFF-8432 and applicable portions of SFF-8431. Digital diagnostics functions are available via a 2-wire serial interface, as specified in SFF- 8472.

I. Absolute Maximum Ratings

Parameter	Symbol	Unit	Min	Max
Storage Temperature Range	T_S	°C	-45	85
Relative Humidity	RH	%	0	95
Supply Voltage	V_{CC}	V	-0.3	3.6

II. Recommended Operating Conditions

Parameter	Symbol	Unit	Min.	Typ.	Max.
Operating Case Temperature Range	T_C	°C	-40		85
Power Supply Voltage	V_{CC}	V	3.14	3.3	3.46
Bit Rate	BR	Gb/s		25.78125	
Max Supported Link Length	L	km			10

III. Electrical Characteristics

Parameter	Symbol	Unit	Min.	Typ.	Max.	Note
Supply Voltage	V_{CC}	V	3.14	3.3	3.46	
Transmitter						
Input Differential Impedance	R_{IN}	Ω		100		
Single Ended Data Input Swing	V_{IN}	mVp-p	90		450	
Transmit Disable Voltage	V_{DIS}	V	2		$V_{CCHOST}+0.3$	
Transmit Enable Voltage	V_{EN}	V	V_{EE}		$V_{EE}+0.8$	
Transmit Fault Assert Voltage	V_{FA}	V	2.4		$V_{CCHOST}+0.3$	
Transmit Fault De-Assert Voltage	V_{FDA}	V	V_{EE}		$V_{EE}+0.4$	
Receiver						
Single Ended Data Output Swing	V_{OD}	mVp-p	225		450	
LOS Fault	V_{LOSFT}	V	2.2		$V_{CCHOST}+0.3$	
LOS Normal	V_{LOSNR}	V	V_{EE}		$V_{EE}+0.4$	

IV. Optical Transmitter/Receiver Characteristics

Parameter	Symbol	Unit	Min.	Typ.	Max.	Note
Transmitter						
Center Wavelength	λ	nm	1295	1310	1325	
Side Mode Suppression Ratio	SMSR	dB	30			
Optical Modulation Amplitude	P_{OMA}	dBm	-4		2.2	
Optical Output Power	P_{avg}	dBm	-4.5		2	
Extinction Ratio	ER	dB	3.5			
Transmitter and Dispersion Penalty	TDP	dB			2.7	
Average Launch Power of OFF Transmitter	P_{OFF}	dBm			-30	
Receiver						
Center Wavelength	λ	nm	1260	1310	1360	
Overload		dBm	2			
Receiver Power(OMA)	P_{OMA}	dBm			-11.4	1
Assert LOS	LOS_A	dBm	-30			
De-Assert LOS	LOS_D	dBm			-15	
LOS Hysteresis		dB	0.5			

Note 1: Measured with 25.78125Gb/s, PRBS 2³¹-1, NRZ, ER>4dB

(tested under recommended operating conditions, unless otherwise noted)

V. Pin Configuration

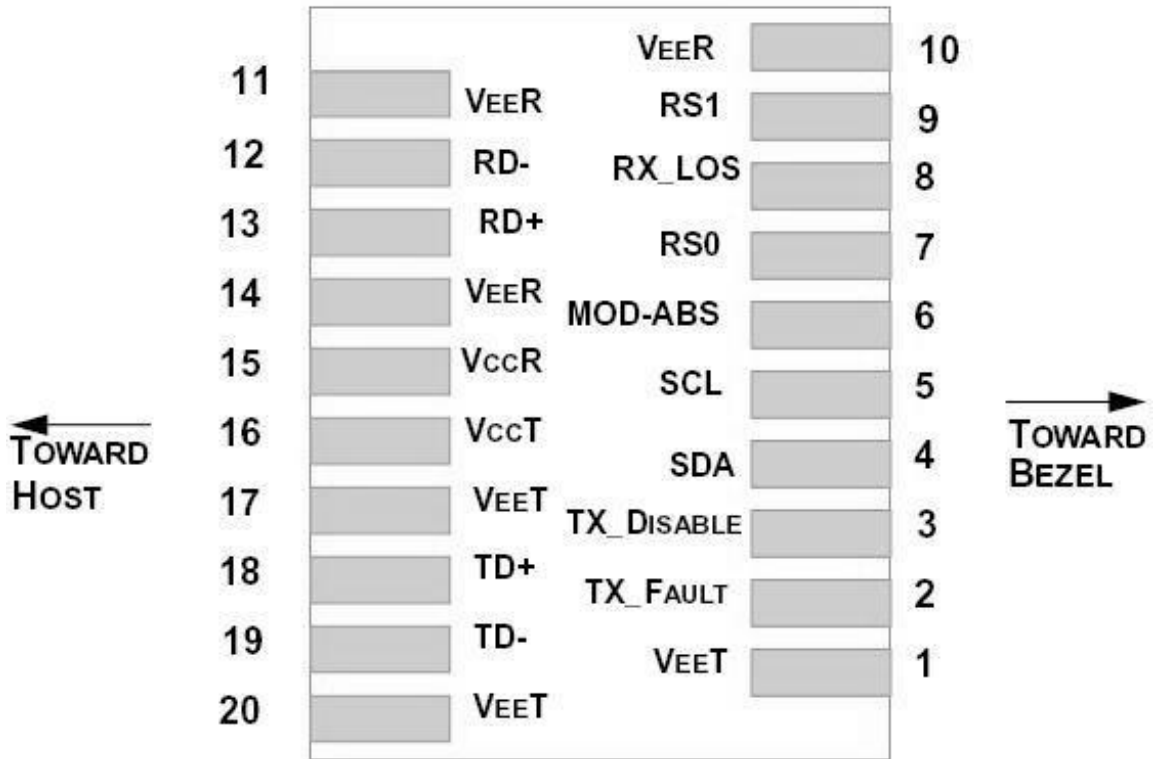

VI. Transceiver Pin Descriptions

Pin No.	Symbol	Logic	Description
1,17,20	$V_{EE}T$		Connected to signal ground on the host board
2	TX Fault	LVTTTL Output	Module transmitter fault output
3	TX Disable	LVTTTL Input	Module transmitter disable control
4	SDA	LVTTTL Input/Output	2-wire serial interface data
5	SCL	LVTTTL Input/Output	2-wire serial interface clock
6	MOD-ABS		Module absent (connected to Module ground)
7	RS0	LVTTTL Input	Rate select 0 (Rx) :Low=CDR Bypass ; High=CDR Select
8	LOS	LVTTTL Output	Receiver loss of signal
9	RS1	LVTTTL Input	Rate select 1 (Tx) :Low=CDR Bypass ; High=CDR Select
10,11,14	$V_{EE}R$		Connected to signal ground on the host board.
12	RD-	CML Output	Receiver inverted data output, internally AC coupled and terminated
13	RD+	CML Output	Receiver non-inverted data output, internally AC coupled and terminated.
15	$V_{CC}R$		Receiver Power 3.3V Supply
16	$V_{CC}T$		Transmitter Power 3.3V Supply
18	TD+	CML Input	Transmitter non-inverted data input, internally AC coupled and terminated.
19	TD-	CML Input	Transmitter inverted data Input, internally AC coupled and terminated.

VII. Principle Diagram

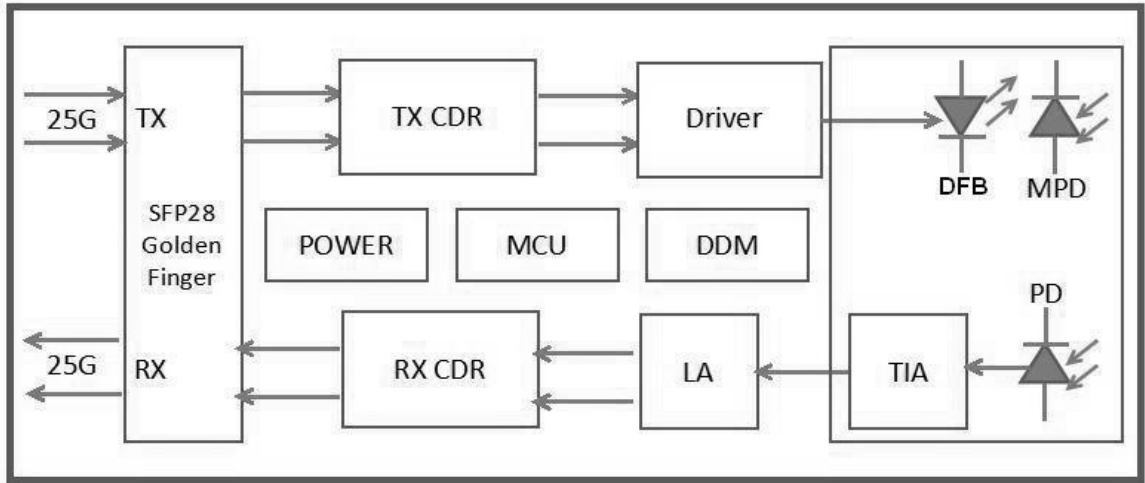

VIII. Mechanical Dimensions

