

# 25GBASE-BX SFP28 1270nmTX/1330nmRX 10km Industrial DOM Transceiver

25G-SFP28-BXU-I-LL

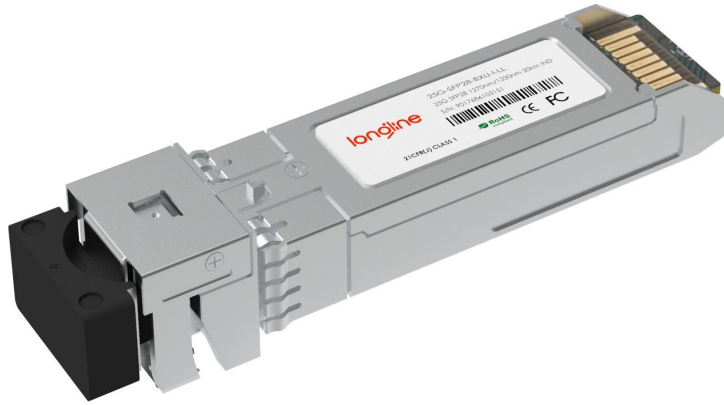

## Application

- 25GBASE-LR
- CPRI Option 10/e CPRI

## Standards

- SFF-8472
- SFF-8402
- SFF-8432
- SFF-8431
- CEI-28G-VSR

## Features

- Up to 10 km Transmission Distance
- Low Power Consumption <1.2W
- Single 3.3V±5% Power Supply
- LC Single Connector
- -40°C to 85°C Operating Case Temperature Range
- Compliant with SFF-8472

## Description

25G BIDI 10KM TX1270nm/RX1330nm is DFB laser based 25 Gb/s SFP28 transceiver. It is designed to transmit and receive optical data up to 10km over single mode fiber. The transceiver is compliant with SFF-8472, SFF- 8402, SFF-8432 and applicable portions of SFF-8431. Digital diagnostics functions are available via a 2-wire serial interface, as specified in SFF- 8472.

## I. Absolute Maximum Ratings

Parameter	Symbol	Unit	Min.	Max.
<b>Storage Temperature Range</b>	$T_S$	°C	-45	85
<b>Relative Humidity</b>	RH	%	0	95
<b>Supply Voltage</b>	$V_{CC}$	V	-0.3	4.0

## II. Recommended Operating Conditions

Parameter	Symbol	Unit	Min.	Typ.	Max.
<b>Operating Case Temperature Range</b>	$T_C$	°C	-40		85
<b>Power Supply Voltage</b>	$V_{CC}$	V	3.135	3.3	3.465
<b>Bit Rate</b>	BR	Gb/s	24.33024		25.78125
<b>Max Supported Link Length</b>	L	km			10

### III. Electrical Characteristics

Parameter	Symbol	Unit	Min.	Typ.	Max.	Note
<b>Supply Voltage</b>	$V_{CC}$	V	3.14	3.3	3.46	

<b>Supply Current</b>	$I_{CC}$	mA			350	@3.3V
-----------------------	----------	----	--	--	-----	-------

#### Transmitter

<b>Input Differential Impedance</b>	$R_{IN}$	$\Omega$		100		
-------------------------------------	----------	----------	--	-----	--	--

<b>Single Ended Data Input Swing</b>	$V_{IN}$	mVp-p	90		450	
--------------------------------------	----------	-------	----	--	-----	--

<b>Transmit Disable Voltage</b>	$V_{DIS}$	V	2		$V_{CCHOST}$	
---------------------------------	-----------	---	---	--	--------------	--

<b>Transmit Enable Voltage</b>	$V_{EN}$	V	$V_{EE}$		$V_{EE}+0.8$	
--------------------------------	----------	---	----------	--	--------------	--

<b>Transmit Fault Assert Voltage</b>	$V_{FA}$	V	2.2		$V_{CCHOST}$	
--------------------------------------	----------	---	-----	--	--------------	--

<b>Transmit Fault De-Assert Voltage</b>	$V_{FDA}$	V	$V_{EE}$		$V_{EE}+0.4$	
---	-----------	---	----------	--	--------------	--

#### Receiver

<b>Single Ended Data Output Swing</b>	$V_{OD}$	mVp-p	200		450	
---------------------------------------	----------	-------	-----	--	-----	--

<b>LOS Fault</b>	$V_{LOSFT}$	V	2.2		$V_{CCHOST}$	
------------------	-------------	---	-----	--	--------------	--

<b>LOS Normal</b>	$V_{LOSNR}$	V	$V_{EE}$		$V_{EE}+0.4$	
-------------------	-------------	---	----------	--	--------------	--

## IV. Optical Characteristics

Parameter	Symbol	Unit	Min.	Typ.	Max.	Note
<b>Transmitter</b>						
<b>Center Wavelength Range</b>	$\lambda$	nm	1260		1280	Upstream
			1320		1340	Downstream
<b>Spectral Width   -20dB</b>		nm			1	
<b>Side Mode Suppression Ratio</b>	SMSR	dB	30			
<b>Average Launch Power</b>	$P_{AVG}$	dBm	-4		2.5	
<b>OMA Launch Power</b>	$P_{OMA}$	dBm	-4			
<b>Transmitter and Dispersion Penalty 25G   BER=5E-5</b>	TDP	dB			2.7	
<b>Average Launch Power of OFF Transmitter</b>	$P_{OFF}$	dBm			-30	
<b>Extinction Ratio</b>	ER	dB	3			
<b>RIN20OMA</b>	$R_{IN}$	dB/Hz			-130	
<b>Optical Return Loss Tolerance</b>		dB			20	
<b>Mask Margin</b>		%	5			1

Parameter	Symbol	Unit	Min.	Typ.	Max.	Note
<b>Receiver</b>						
<b>Center Wavelength</b>	$\lambda$	nm	1320	1330	1340	Upstream
			1260	1270	1280	Downstream
<b>Overload</b>		dBm	2.5			
<b>OMA Receiver Sensitivity Up to 25G 5E-5</b>	P <sub>OMA</sub>	dBm			-12	
<b>Assert LOS</b>	LOS <sub>A</sub>	dBm	-30			
<b>De-Assert LOS</b>	LOS <sub>D</sub>	dBm			-15	
<b>LOS Hysteresis</b>		dB	0.5			

### V. Pin Configuration

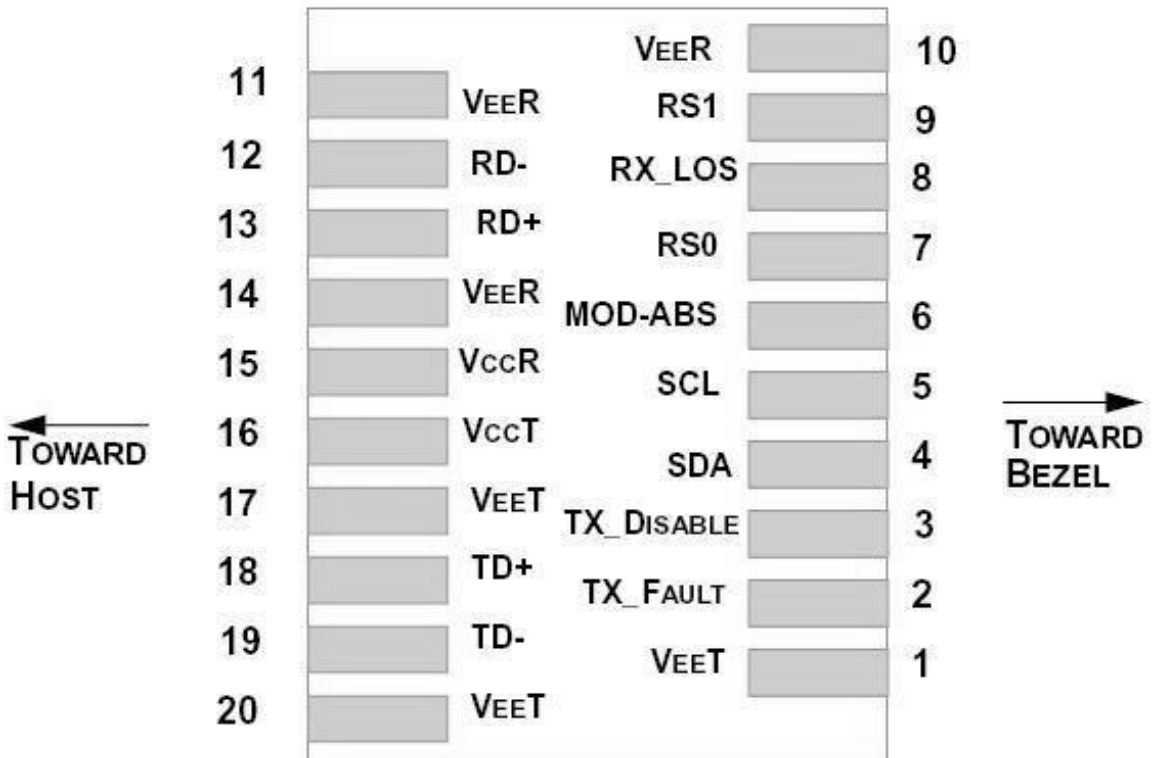

## VI. Transceiver Pin Descriptions

Pin No.	Symbol	Logic	Description
1,17,20	V <sub>EE</sub> T		Connected to signal ground on the host board
2	TX Fault	LVTTTL Output	Module transmitter fault output
3	TX Disable	LVTTTL Input	Module transmitter disable control
4	SDA	LVTTTL Input/Output	2-wire serial interface data
5	SCL	LVTTTL Input/Output	2-wire serial interface clock
6	MOD-ABS		Module absent (connected to Module ground)
7	RS0	LVTTTL Input	Rate select 0 (Rx) :Low=CDR Bypass ; High=CDR Select
8	LOS	LVTTTL Output	Receiver loss of signal
9	RS1	LVTTTL Input	Rate select 1 (Tx) :Low=CDR Bypass ; High=CDR Select
10,11,14	V <sub>EE</sub> R		Connected to signal ground on the host board.
12	RD-	CML Output	Receiver inverted data output, internally AC coupled and terminated
13	RD+	CML Output	Receiver non-inverted data output, internally AC coupled and terminated.
15	V <sub>CC</sub> R		Receiver power 3.3V supply
16	V <sub>CC</sub> T		Transmitter power 3.3V supply
18	TD+	CML Input	Transmitter non-inverted data input, internally AC coupled and terminated.
19	TD-	CML Input	Transmitter inverted data Input, internally AC coupled and terminated.

## VII. Principle Diagram

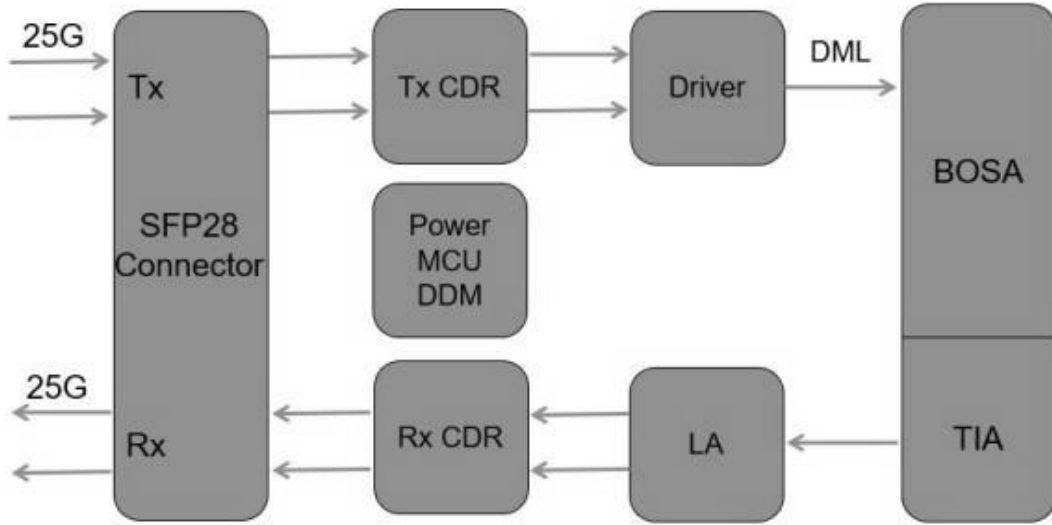

## VIII. Mechanical Dimensions

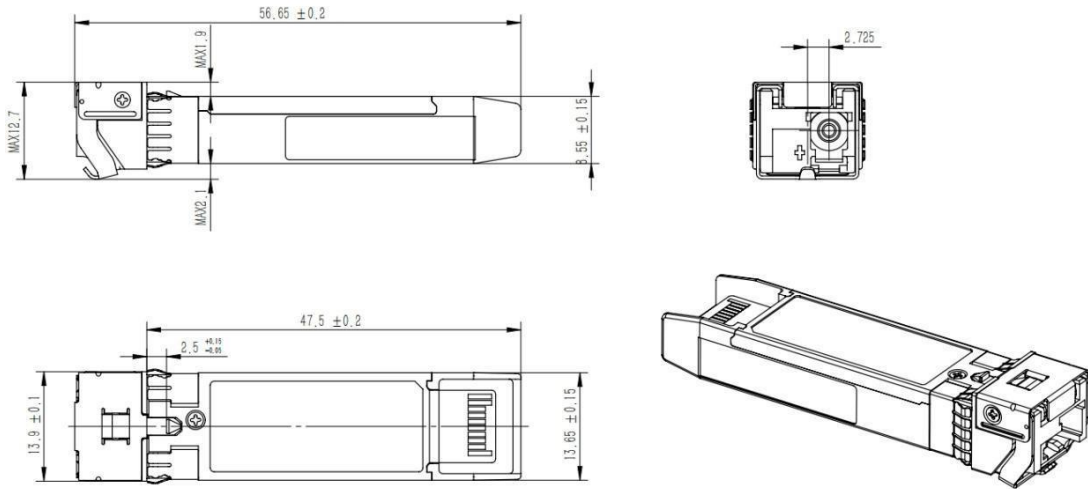

Unit, mm  
Unspecified Tolerance,  $\pm 0.1$ mm