

10GBASE-ER SFP+ 1310nm 40km Industrial DOM Transceiver

10G-SFPP-ER40-I-LL

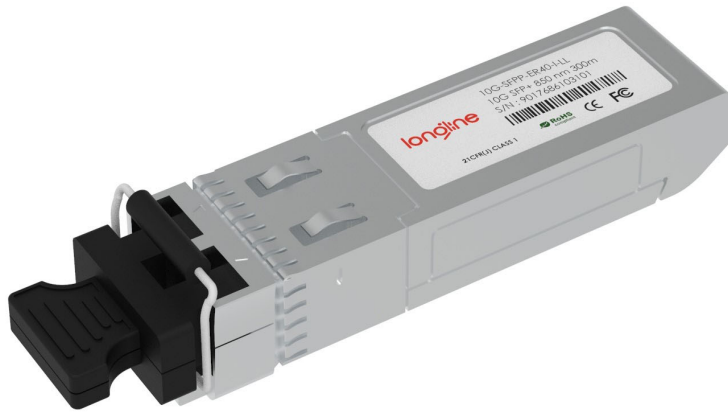

Application

- 10GBASE-LR/LW 10G
- Ethernet
- 10GFC
- 8GFC

Features

- Hot-pluggable SFP+ footprint
- Link lengths at 10G 30Km with DFB 1310nm
- Supports 6.1 Gb/s to 10.52 Gb/s
- Un-cooled 1310nm DFB laser
- Receiver limiting electrical interface
- Power dissipation < 1.3W
- -40°C to 85°C temperature range
- RoHS-6 compliant (lead-free)
- Single 3.3V power supply
- Duplex LC connector
- Built-in digital diagnostic functions

Description

The 10Gigabit 1310nm DFB Transceiver is designed to transmit and receive serial optical data links up from 6.1 Gb/s to 10.52 Gb/s data rate over 30km singlemode fiber. The Transceiver is compliant with SFF-8432, 10GFC, FC-PI-4, IEEE802.3ae and applicable portions of SFF-8431. Digital diagnostics functions are available via a 2-wire serial interface, as specified in SFF-8472.

Product Specifications

I. Absolute Maximum Ratings

Parameter	Symbol	Min	Typ.	Max	Unit	Ref.
Maximum Supply Voltage	Vcc	-0.3		4.0	V	
Storage Temperature	Ts	-40		85	°C	
Relative Humidity	RH	0		95	%	

II.Recommended Operating Conditions

Parameter	Symbol	Min	Typ.	Max	Unit	Ref.
Operating Case Temperature Range	Tc	-40		85	°C	
Power Supply Voltage	Vcc	3.14	3.3	3.46	V	
Bit Rate	BR	6.1		10.52	Gb/s	
Bit Error Ratio	BER			10 ⁻¹²		
Max Supported Link Length	L			30	km	

III. Principle Diagram

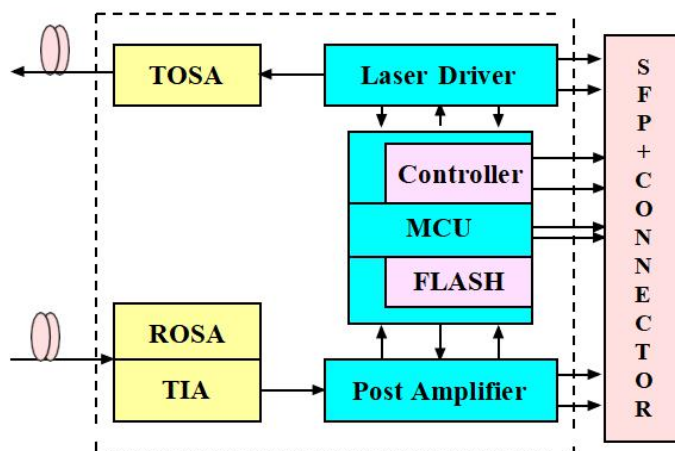

IV. Electrical Characteristics (TOP = -40 to 85 °C, VCC = 3.14 to 3.46 V)

Parameter	Symbol	Min	Typ.	Max	Unit	Ref.
Supply Voltage	V _{CC}	3.14	3.30	3.46	V	
Supply Current	I _{CC}			390	mA	
Transmitter						
Input differential impedance	R _{IN}	80	100	120	Ω	1
Differential data input swing	V _{IN}	180		700	mVp-p	
Transmit Disable Voltage	V _{DIS}	2		V _{CCHOST}	V	
Transmit Enable Voltage	V _{EN}	V _{EE}		V _{EE} +0.8	V	
Transmit Fault Assert Voltage	V _{FA}	2.2		V _{CCHOST}	V	
Transmit Fault De-Assert Voltage	V _{FDA}	V _{EE}		V _{EE} +0.4	V	
Receiver						
Differential data output swing	V _{OD}	450	600	850	mVp-p	
Output rise time and fall time	T _r , T _f	25			ps	
LOS Fault	V _{LOSFT}	2		V _{CCHOS}	V	
LOS Normal	V _{LOSNR}	V _{EE}		V _{EE} +0.8	V	

Notes:

1. NOTE 1: Differential between TD+ / TD-

V. Optical Characteristics (TOP = -40 to 85 °C, VCC = 3.14 to 3.46 V)

Parameter	Symbol	Min	Typ.	Max	Unit	Note
Transmitter (Tx)						
Nominal Wavelength	λ	1260	1310	1355	nm	
Side Mode Suppression Ratio	SMSR	30			dB	
Spectral width	$\Delta\lambda$	nm		1		
Optical Output Power	P_{AV}			1 3	dBm	20km 30km
Optical Modulation Amplitude ¹	P_{OMA}	-5 -1			dBm	20km 30km
Extinction Ratio	ER	3.5			dB	
Average launch power of OFF transmitter	P_{OFF}			-35	dBm	
Relative Intensity Noise	R_{IN}			-128	dB/Hz	
Optical Return Loss Tolerance	ORLT	-15			dB	
Receiver (Rx)						
Center Wavelength	λ	1260		1610	nm	
Average Receiver Power	P_{AVG}			+1	dBm	
Receiver Sensitivity ² (OMA)	R_{SENSE1}			-15	dBm	
Receiver Reflectance	R_{REFL}			-15	dB	

VII. Pin Description

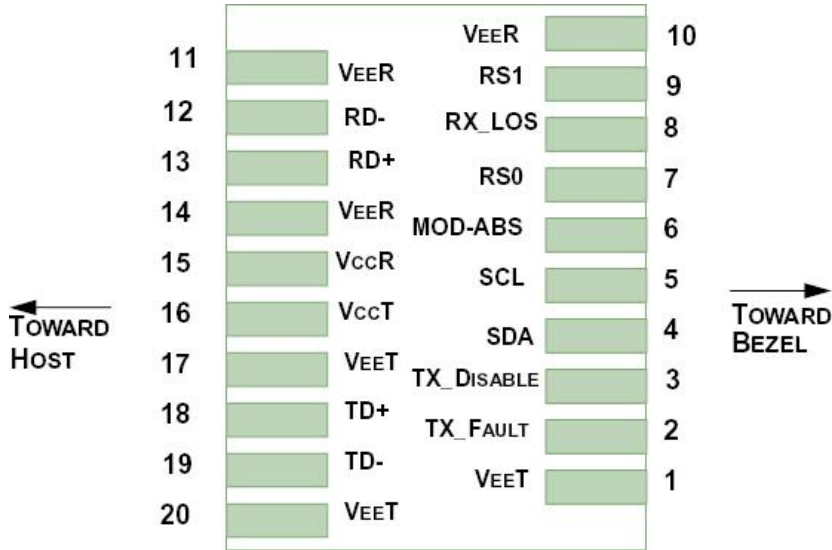

Figure 1 – Diagram of Host Board Connector Block Pin Numbers and Names.

Pin	Symbol	Name/Description	Notes
1	VEET	Transmitter Ground	1
2	TFAULT	Transmitter Fault	2
3	TDIS	Transmitter Disable. Laser output disabled on high or open.	3
4	SDA	2-wire Serial Interface Data Line	2
5	SCL	2-wire Serial Interface Clock Line	2
6	MOD_ABS	Module Absent. Grounded within the module	2
7	RS0	Rate Select 0.	4
8	RX_LOS	Loss of Signal indication. Logic 0 indicates normal operation.	5
9	RS1	Rate Select 1.	4

10	VEER	Receiver Ground	1
11	VEER	Receiver Ground	1
12	RD-	Receiver Inverted DATA out. AC Coupled.	
13	RD+	Receiver Non-inverted DATA out. AC Coupled.	
14	VEER	Receiver Ground	1
15	VCCR	Receiver Power Supply	
16	VCCT	Transmitter Power Supply	
17	VEET	Transmitter Ground	1
18	TD+	Transmitter Non-Inverted DATA in. AC Coupled.	
19	TD-	Transmitter Inverted DATA in. AC Coupled.	
20	VEET	Transmitter Ground	1

Notes:

1. Circuit ground is internally isolated from chassis ground.
2. TFAULT is an open collector/drain output, which should be pulled up with a 4.7k -10k Ohms resistor on the host board if intended for use. Pull up voltage should be transmitter fault caused by either the TX bias current or the TX output power exceeding the preset alarm thresholds. A low output indicates normal operation. In the low state, the output is pulled to <0.8V.
3. Laser output disabled on TDIS >2.0V or open, enabled on TDIS <0.8V.
4. Internally pulled down per SFF-8431 Rev 2.0. See Sec. X for the logic table to use for the internal CDRs locking modes.
5. LOS is open collector output. Should be pulled up with 4.7kΩ -10kΩ on host board to a voltage between 2.0V and 3.6V. Logic 0 indicates normal operation; logic 1 indicates loss of signal.

VIII. Typical Application Circuit

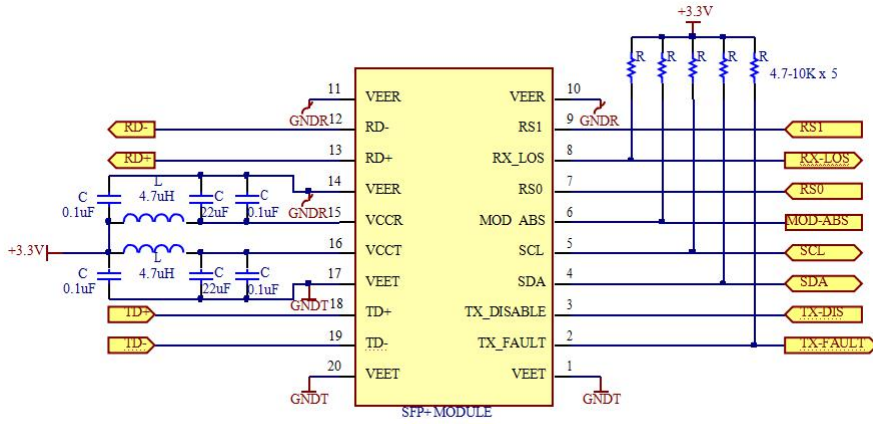

IX. Mechanical Specifications

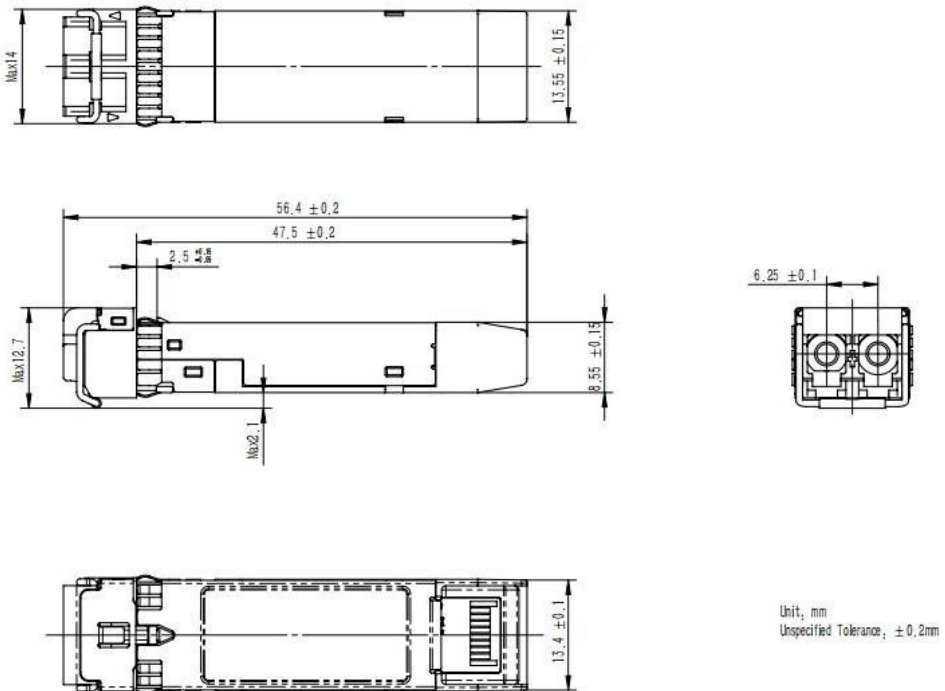

X. Regulatory Compliance

Feature	Test Method	Performance
Electrostatic Discharge (ESD) to the Electrical Pins	MIL-STD-883C Method 3015.7	Class 1 (> 1500 Volts)
Electrostatic Discharge (ESD) Immunity	Variation of IEC 61000-4-2	LV 4(Air discharge :15KV;Contact discharge:8 KV) Performance criterion:B
Electromagnetic Interference (EMI)	CISPR22 ITE Class B EN55022 Class B FCC Class B	Compliant with standards
Immunity	IEC61000-4-3 Class 2 EN55024	Typically show no measurable effect from a 3V/m field swept from 80 to 1000MHz applied to the transceiver without a chassis enclosure.