

# 10GBASE-SR SFP+ 850nm 300m Industrial DOM Transceiver

10301-I-LL

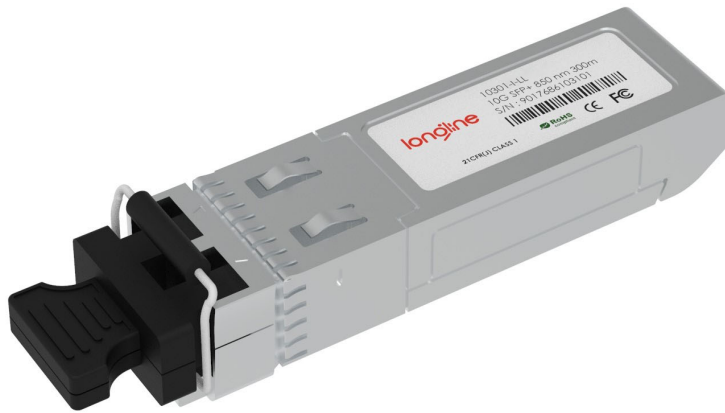

## Application

- 10GBASE-SR/SW
- OBSAI and CPRI application
- Other Optical Links

## Features

- Operating Data Rate up to 10.31Gbps
- 850nm VCSEL Laser Transmitter
- 300m with 50/125  $\mu$ m MMF
- Single 3.3V Power Supply and TTL Logic Interface
- Hot-Pluggable SFP+ Footprint Duplex LC Connector Interface
- Power Dissipation < 1.0W
- Dispersion tolerance up to 40ps/nm over G.651
- Operating Case Temperature: -40°C~+85°C
- Compliant with MSA SFP+ Specification SFF-8431
- Compliant with IEEE802.3ae 10GBASE-SR/SW
- Fully ROHS 2.0 compliant

## Description

The 10G 850NM 300m 850nm VCSEL 10Gigabit Transceiver is designed to transmit and receive serial optical data links up to 10.3125 Gb/s data rate over multimode fiber. The Transceiver is compliant with FC-PI-4, 10G FC, IEEE 802.3ae, SFF-8432, and applicable portions of SFF-8431. The transmitter converts serial CML electrical data into serial optical data. An open collector compatible Transmit Disable (Tx\_Dis) is provided. When TX\_DIS is asserted High, Transmitter is turned off. The receiver converts serial optical data into serial CML electrical data. An open collector compatible Loss of Signal is provided. The RX\_LOS signal indicates insufficient optical power for reliable signal reception at the receiver. Digital diagnostics functions are available via a 2-wire serial interface, as specified in SFF-8472.

## Product Specifications

### I. Block diagram

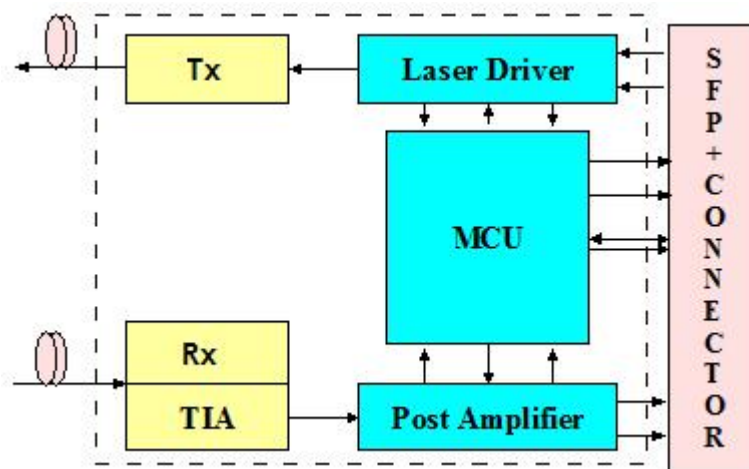

Figure 1 Transceiver functional diagram

### II. Absolute Maximum Ratings

Parameter	Symbol	Unit	Min.	Max.
<b>Storage Temperature Range</b>	T <sub>s</sub>	°C	-40	85
<b>Relative Humidity</b>	RH	%	0	85
<b>Supply Voltage</b>	VCC	V	-0.3	4

### III. Recommended Operating Conditions

Parameters	Unit	min	type	max
<b>Form factor</b>			SFP+	
<b>Data Rate</b>	Gb/s		9.953/10.3125	
<b>Applications</b>	-		10GBASE-SR/SW, OBSAI, CPRI	
<b>Optical Receptacle type</b>	LC/SC		LC	
<b>Fiber Type</b>	SMF/MMF		MMF	
<b>Fiber distance</b>	Km			0.3
<b>Power Consumption</b>	W			1
<b>Operating Case Temperature</b>	°C	-40		85
<b>DDM Calibration Type</b>			Inside Calibration	
<b>Rate select function</b>			no request	
<b>IIC Clock frequency</b>	KHz	100		400
<b>IIC clock stretching</b>	us			500
<b>IIC tHD: Data hold time</b>	ns	300		

### IV. Electrical Characteristics

(T<sub>c</sub>=-40°C to 85°C, V<sub>cc</sub>= 3.135 to 3.465V, Data rate: 10.3125Gb/s)

Parameters	Unit	min	type	max
<b>Supply voltage</b>	V	3.135	3.30	3.465
<b>Supply current</b>	mA		-	300

<b>Maximum sustained peak Current(&lt;500ms)</b>	mA			600	
<b>Input differential impedance</b>	$\Omega$		100		
<b>Differential data input swing</b>	mV	300		1200	
<b>Differential data output swing</b>	mV	300		1000	
<b>LOS Squelch(Yes&amp;No)</b>		Yes			
<b>Tx Fault, LOS Output Voltage</b>	High	V	2.0		VCC
	Low	V	VEE		VEE+0.8
<b>Tx Disable</b>	VIL	V	2.0		VCC
	VIH	V	VEE		VEE+0.8

## V. Optical Characteristics

(T<sub>c</sub>=-40°C to 85°C, V<sub>cc</sub>= 3.135 to 3.465V, Data rate: 10.3125Gb/s)

Parameters	Unit	min	type	max
------------	------	-----	------	-----

### Transmitter optical characteristics

<b>Laser type</b>			VCSEL	
<b>Output average power</b>	dBm	-6.0		-1
<b>Center wavelength</b>	nm		850	
<b>Wavelength range</b>	nm	840		860
<b>Spectral width</b>	nm			0.45

<b>Extinction ratio ER</b>	dB	3		
<b>Eye Mask Margin(1000consecutive snapshots at typical rate and room temperature)</b>		IEEE 802.3-2005 Compliant		
<b>Transmitter and Dispersion Penalty</b>	dB	3.9		
<b>RIN12OMA</b>	dB/Hz			-128
<b>Optical Power for TX DISABLE</b>	dBm	-40		
<b>Optical return loss tolerance</b>	dB			12

**Receiver Optical Characteristics**

<b>Operating wavelength</b>	nm	840		860
<b>Sensitivity</b>	dBm	-11.1		
<b>Saturation power</b>	dBm	-1		
<b>Max Input power</b>	dBm	0.5		
<b>LOS</b>	Assert	dBm	-25	
	De-assert	dBm		-12.5
	Hysteresis	dB	0.5	6
<b>Optical Return Loss</b>	dB	12		

**VI. Pin function definitions**

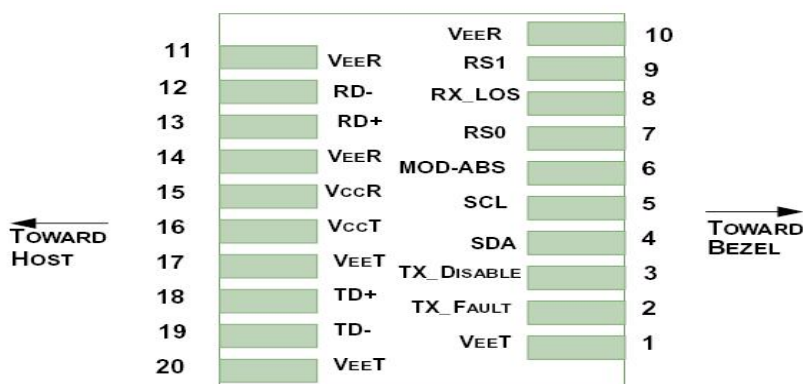

## VII. Transceiver Pin Descriptions

Pin Number	Symbol	Name	Description
<b>1,17,20</b>	VeeT	Transmitter Signal Ground	These pins should be connected to signal ground on the host board.
<b>2</b>	TX Fault	Transmitter Fault Out (OC)	Logic "1" Output = Laser Fault (Laser off before $t_{fault}$ ) Logic "0" Output = Normal Operation This pin is open collector compatible, and should be pulled up to Host Vcc with a 10k $\Omega$ resistor.
<b>3</b>	TX Disable	Transmitter Disable In (LVTTTL)	Logic "1" Input (or no connection) = Laser off Logic "0" Input = Laser on This pin is internally pulled up to VccT with a 10 k $\Omega$ resistor.
<b>4</b>	SDA	Module Definition Identifiers	Serial ID with SFF 8472 Diagnostics Module Definition pins should be pulled up to Host Vcc with 10 k $\Omega$ resistors.
<b>5</b>	SCL		
<b>6</b>	MOD-ABS		
<b>7</b>	RS0	Receiver Rate Select (LVTTTL) Transmitter Rate Select (LVTTTL)	These pins have an internal 30k $\Omega$ pull-down to ground. A signal on either of these pins will not affect module performance.
<b>9</b>	RS1		
<b>8</b>	LOS	Loss of Signal Out (OC)	Sufficient optical signal for potential BER < 1x10 <sup>-12</sup> = Logic "0" Insufficient optical signal for potential BER < 1x10 <sup>-12</sup> = Logic "1" This pin is open collector compatible, and should be pulled up to Host Vcc with a 10k $\Omega$ resistor.
<b>10,11,14</b>	VeeR	Receiver Signal Ground	These pins should be connected to signal ground on the host board.
<b>12</b>	RD-	Receiver Negative DATA Out	Light on = Logic "0" Output Receiver DATA output is internally AC coupled and series terminated with a 50 $\Omega$ resistor.
<b>13</b>	RD+	Receiver Positive DATA Out	Light on = Logic "1" Output Receiver DATA output is internally AC coupled and series terminated with a 50 $\Omega$ resistor.
<b>15</b>	VccR	Receiver Power Supply	This pin should be connected to a filtered +3.3V power supply on the host board. See Figure 3. Recommended power supply filter
<b>16</b>	VccT	Transmitter Power Supply	This pin should be connected to a filtered +3.3V power supply on the host board. See Figure 3. Recommended power supply filter
<b>18</b>	TD+	Transmitter Positive DATA In	Logic "1" Input = Light on Transmitter DATA inputs are internally AC coupled and terminated with a differential 100 $\Omega$ resistor.
<b>19</b>	TD-	Transmitter Negative DATA In	Logic "0" Input = Light on Transmitter DATA inputs are internally AC coupled and terminated with a differential 100 $\Omega$ resistor.

### VIII. Digital Diagnostic Interface Definition

The 2-wire serial interface addresses of the SFP+ module are 1010000x (A0h) and 1010001x (A2h). They are shown in Figure 4.

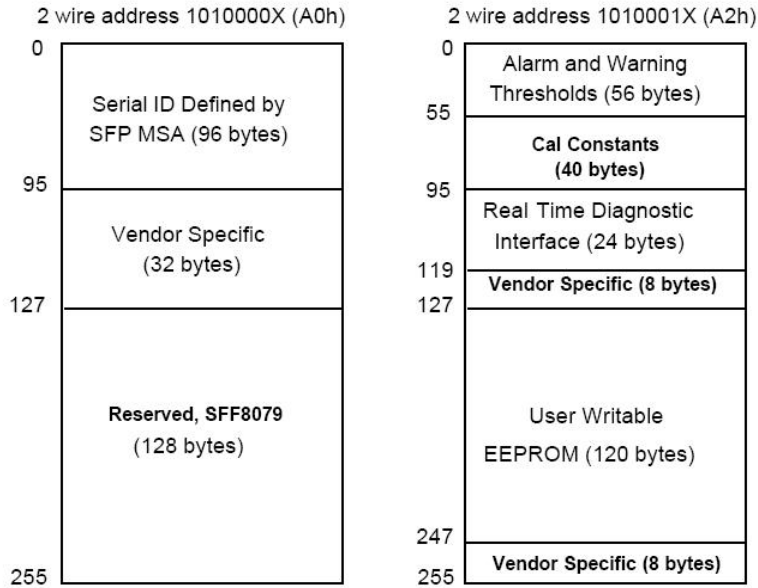

Figure 4 Digital Diagnostic Memory Map

### IX. Electrostatic Discharge (ESD).

The 10G 850NM 300m is compatible with ESD levels found in typical manufacturing and operating environments as described in Table Regulatory compliance. In the normal handling and operation of optical transceivers, ESD is of concern in two circumstances.

The first case is during handling of the transceiver prior to insertion into an SFP+ compliant cage. To protect the device, it's important to use normal ESD handling pre-cautions. These include use of grounded wrist straps, work-benches and floor wherever a transceiver is handled.

The second case to consider is static discharges to the exterior of the host equipment chassis after installation. If the optical interface is exposed to the exterior of host equipment cabinet, the transceiver may be subject to system level ESD requirements.

### X. Electromagnetic Interference (EMI).

Equipment incorporating gigabit transceivers is typically subject to regulation by the FCC in the United States, CENELEC EN55022 (CISPR 22) in Europe. The 10G 850NM 300m compliance to these standards is detailed in Table Regulatory compliance. The metal housing and shielded design of the 10G 850NM 300m minimizes the EMI challenge facing the equipment designer.

### XI. EMI Immunity (Susceptibility)

Due to its shielded design, the EMI immunity of the 10G 850NM 300m exceeds typical industry standards.

## XII. Regulatory compliance

Feature	Test Method	Performance
<b>Electrostatic Discharge (ESD) to the Electrical Pins</b>	MIL-STD-883C Method 3015.7	Class 1 (> 1500 Volts)
<b>Electrostatic Discharge (ESD) to the Duplex LC Receptacle</b>	Variation of IEC 61000-4-2	Typically, no damage occurs with 15 kV when the duplex LC connector receptacle is contacted by a Human Body Model probe.
<b>Electromagnetic Interference (EMI)</b>	CISPR22 ITE Class B EN55022 Class B FCC Class B	Compliant with standards
<b>Immunity</b>	IEC61000-4-3 Class 2 EN55024	Typically show no measurable effect from a 3V/m field swept from 80 to 1000MHz applied to the transceiver without a chassis enclosure.

## XIII. Typical application circuit

Recommended "Typical Application Schematics" are shown in Figure 3.

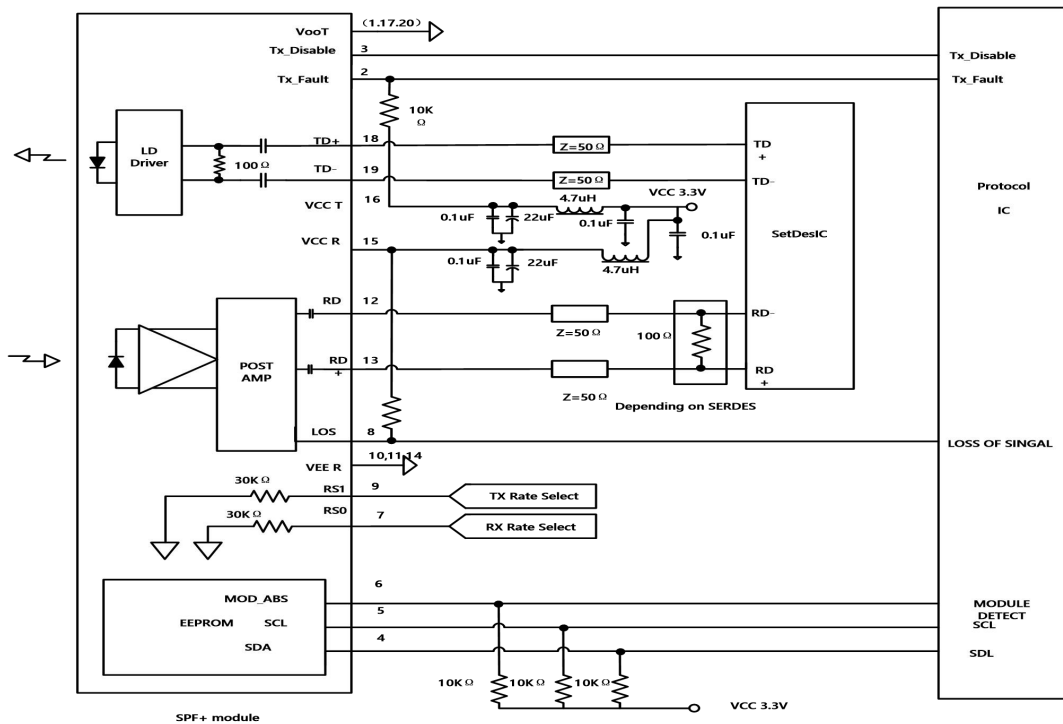

Figure 3 Typical application schematics



## XIV. Diagnostic Monitor Functions

Diagnostic Monitor Functions interface uses the 2 wire address 1010001X (A2). Memory contents of Diagnostic Monitor Functions are shown in table below.

## XV. Memory contents of Diagnostic Monitor Function

### 1) DDM threshold

Parameters	High Alarm	Low Alarm	High Warning	Low Warning
<b>temperature</b>	95	-50	85	-40
<b>voltage</b>	3.6	3	3.5	3.1
<b>Ibias</b>	12	1	10	2
<b>Tx power</b>	1	-8	-1	-6
<b>Rx power</b>	1	-13.1	-1	-11.1

### 2) DDM accuracy requirements

Parameters	Unit	Requirements
<b>temperature</b>	°C	+/-3
<b>voltage</b>	V	+/-3%
<b>Ibias</b>	mA	+/-10%
<b>Tx power</b>	dB	+/-3dB
<b>Rx power</b>	dB	+/-3dB

### 3) DDM enhanced options

Parameters	Requirements
<b>Soft Tx-disable</b>	support
<b>Soft Tx-fault</b>	support
<b>Soft Rx-los</b>	support

## XVI. Package outline

