

10GBASE-LR SFP+ 1310nm 10km Industrial DOM Transceiver

0231A0A8-I-LL



Application

- 10GBASE-LR/LW 10G Ethernet
- 8G/10GFC
- CPRI rates 2.4576 Gb/s, 4.9152Gb/s, 6.144Gb/s, 9.8304 Gb/s

Features

- Hot-pluggable SFP+ footprint
- Supports 9.95 to 10.52Gb/s bit rates
- Power dissipation < 1W
- RoHS-6 compliant (lead-free)
- Industrial temperature range : -40°C to 85°C
- Single 3.3V power supply
- Maximum link length of 10km
- Uncooled 1310nm DFB laser
- Receiver limiting electrical interface
- Duplex LC connector
- Built-in digital diagnostic functions

Description

The 10G LR 10Gigabit 1310nm DFB Transceiver is designed to transmit and receive serial optical data links up from 2.1 Gb/s to 10.52 Gb/s data rate over 10km singlemode fiber. The Transceiver is compliant with SFF-8432, 10GFC, FC-PI-4, IEEE802.3ae and applicable portions of SFF-8431. Digital diagnostics functions are available via a 2-wire serial interface, as specified in SFF-8472.

Product Specifications

I. General Specifications

Data Rate Specifications	Symbol	Min	Typ.	Max	Units	Ref.
Bit Rate	BR	2.1		10.52	Gb/s	1
Bit Error Ratio	BER			10 ⁻¹²		2
Max. Supported Link Length	L MAX			40	km	1

Notes:

1. 10GBASE-LR, 10GBASE-LW, 1200-SM-LL-L 10GFC.
2. Tested with a 2³¹ – 1 PRBS.

II. Absolute Maximum Ratings

Parameter	Symbol	Min	Typ.	Max	Unit	Ref.
Maximum Supply Voltage	V _{CC}	-0.5		4.0	V	
Storage Temperature	T _S	-40		85	°C	
Case Operating Temperature	T _{OP}	-40		85	°C	
Relative Humidity	RH	0		85	%	1
Receiver Optical Damage Threshold	RxDamage	5			dBm	

Note:

Non-condensing.

III. Electrical Characteristics (TOP = -40 to 85 °C, VCC = 3.14 to 3.46 V)

Parameter	Symbol	Min	Typ.	Max	Unit	Ref.
Supply Voltage	V _{CC}	3.14	3.30	3.46	V	
Supply Current	I _{CC}		200	285	mA	
Transmitter						
Input differential impedance	R _{in}	80	100	120	Ω	1
Differential data input swing	V _{in,pp}	180		700	mV _{pp}	
Transmit Disable Voltage	V _D	2		V _{OCHOST}	V	
Transmit Enable Voltage	V _{EN}	V _{EE}		V _{EE} +0.8	V	
Transmit Fault Assert Voltage	V _{FA}	22		V _{OCHOST}	V	
Transmit Fault De-Assert Voltage	V _{FDA}	V _{EE}		V _{EE} +0.4	V	

Receiver

Differential data output swing	V_{OD}	450	600	850	mVp-p
Output rise time and fall time	T_r, T_f	25			ps
LOS Fault	V_{LOSFT}	2		V_{CCHOST}	V
LOS Normal	V_{LOSNR}	V_{EE}		$V_{EE}+0.8$	V

Notes:

1. Connected directly to TX data input pins. AC coupling from pins into laser driver IC.
2. Into 100 differential termination.
3. 20 – 80%. Measured with Module Compliance Test Board and OMA test pattern. Use of four 1' s and four 0' s sequence in the PRBS 9 is an acceptable alternative.
4. LOS is an open collector output. Should be pulled up with 4.7k – 10k on the host board. Normal operation is logic 0; loss of signal is logic 1.
5. The transceiver is a “limiting module” , i.e., it employs a limiting receiver. Host board designers using an EDC PHY IC should follow the IC manufacturer' s recommended settings for interoperating the host-board EDC PHY with a limiting receiver SFP+ module.

IV. Optical Characteristics (TOP = -40 to 85 °C, VCC = 3.14 to 3.46 V)

Parameter	Symbol	Min	Typ.	Max	Unit	Note
Transmitter						
Optical Modulation Amplitude (OMA)	P_{OMA}	-5.2			dBm	
Average Launch Power	P_{AVE}	-8.2		+0.5	dBm	1
Optical Wavelength	λ	1260		1360	nm	
Side-Mode Suppression Ratio	SMSR	30			dB	
Optical Extinction Ratio	ER	3.5			dB	
Transmitter and Dispersion Penalty	TDP			3.2	dB	
Average Launch power when Tx is OFF	P_{OFF}			-35	dBm	
Relative Intensity Noise	RIN			-128	dB/Hz	
Receiver						
Receiver Sensitivity (OMA) @ 10.3Gb/S	R_{SENS1}			-12.6	dBm	2
Receiver Sensitivity (OMA) @ 10.3Gb/s	R_{SENS2}			-10.3	dBm	3
Average Receive Power	P_{AVE}	-14.2		+0.5	dBm	
Optical Center Wavelength	λ_C	1260		1610	nm	
Receiver Reflectance	R_{RX}			-12	dB	

LOS De-Assert	LOS De-Assert	LOS_D	-17																dBm																							
	LOS Assert	LOS_A	-30																		dBm																					

Notes:

- Sensitivity for 10G PRBS 231-1 and BER better than or equal to $10E-12$
- The stressed sensitivity value in the table are for system level BER measurements which include the effects of CDR circuit.

V. Digital Diagnostic Specifications

10GBASE-LR SFP+ transceivers can be used in host systems that require either internally or externally calibrated digital diagnostics.

Parameter	Symbol	Min	Typ.	Max	Units	Ref.
-----------	--------	-----	------	-----	-------	------

Accuracy

Internally measured transceiver temperature	$\Delta DD_{Temperature}$			3	°C	
Internally measured transceiver supply voltage	$\Delta DD_{Voltage}$			3	%	
Measured TX bias current	ΔDD_{Bias}			10	%	1
Measured TX output power	$\Delta DD_{Tx-Power}$			2	dB	
Measured RX received average optical power	$\Delta DD_{Rx-Powe}$			2	dB	

Dynamic Range for Rated Accuracy

Internally measured transceiver temperature	DDTemperature	-40	85	°C
Internally measured transceiver temperature	DDVoltage	3.1	3.5	V
Measured TX bias current	DDBias	10	90	mA
Measured TX output power	DDTx-Power	-8.2	+0.5	dBm
Measured RX received average optical power	DDRx-Powe	-14.2	+0.5	dBm

Max Reporting Range

Internally measured transceiver temperature	DDTemperature	-40	125	°C
Internally measured transceiver supply voltage	DDVoltage	2.8	4.0	V
Measured TX bias current	DDBias	0	20	mA
Measured TX output power	DDTx-Power	-10	+2	dBm
Measured RX received average optical power	DDRx-Power	-22	+2	dBm

Notes:

Accuracy of measured Tx bias current is 10% of the actual bias current from the laser driver to the laser.

VI. Pin Description

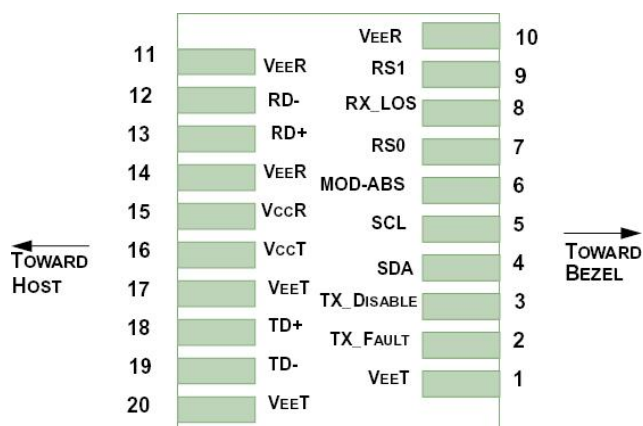

Pin	Symbol	Name/Description	Ref.
1	V _{EET}	Transmitter Ground	1
2	T _{FAULT}	Transmitter Fault	2
3	T _{DIS}	Transmitter Disable. Laser output disabled on high or open.	3
4	SDA	2-wire Serial Interface Data Line	2
5	SCL	2-wire Serial Interface Clock Line	2
6	MOD_ABS	Module Absent. Grounded within the module	2
7	RS0	Rate Select 0.	4
8	RX_LOS	Loss of Signal indication. Logic 0 indicates normal operation.	5
9	RS1	Rate Select 1.	4
10	V _{EER}	Receiver Ground	1
11	V _{EER}	Receiver Ground	1
12	RD-	Receiver Inverted DATA out. AC Coupled.	
13	RD+	Receiver Non-inverted DATA out. AC Coupled.	
14	V _{EER}	Receiver Ground	1

15	V _{CCR}	Receiver Power Supply	
16	V _{CCT}	Transmitter Power Supply	
17	V _{EET}	Transmitter Ground	1
18	TD+	Transmitter Non-Inverted DATA in. AC Coupled.	
19	TD-	Transmitter Inverted DATA in. AC Coupled.	
20	V _{EET}	Transmitter Ground	1

VII. Typical Application Circuit

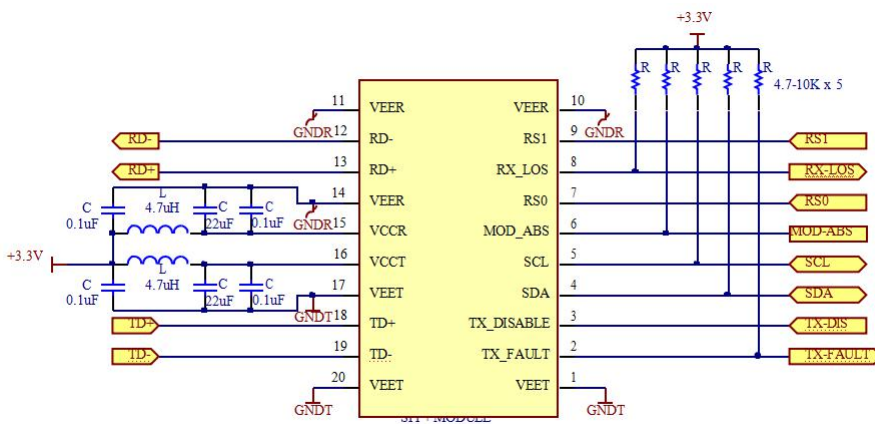

VIII. Mechanical Specifications

